



GREAT LAKES WATERCROSS AM REC LITES



AQUABIKE GP OF ITALY

PRORIDER™

WATERCROSS MAGAZINE



2025 YAMAHA

JETBLASTER® WAVERUNNER®

- AUSTRALIA NATIONALS
- WESTCOAST SURF RIDERS
- JETTRIBE NAUTIWATER RACING
- AZ PWC ENTHUSIASTS
- HOOVER DAM RIDE
- EAST COAST WATERCROSS
- KENTUCKY PWC RIDERS
- WATERFALL EXTRAVAGANZA
- LIQUI MOLY PRO WATERCROSS
- TRIPLE CROWN
- BAHAMAS CHALLENGE
- TEAM GOATCHER MONSTER WATERCRAFT BUILD
- HOT PRODUCTS BEST OF THE WEST SERIES
- JET SKI ODYSSEY CROATIA
- WILD WEST WATERCROSS
- NAUTIGIRL CREW POKER RUN
- WOMEN'S WAVEBLASTER CLASS
- GIWA NATIONAL TOUR
- + MORE!



LSP REVOLVER S1 POWERED BY SBT



**SCAN
ME**



WWW.JETSKIPARTS.JP

ありがとう

"arigatou" Japanese word means "Thank you"

JET★STAR





Introducing the exciting 2025 Yamaha JetBlaster® WaveRunner® Series page 72

PRO RIDER FEATURES



26



36



46



52



68

DEPARTMENTS

SOCIAL MEDIA	6
PUBLISHER LETTER	8
STARTING LINE	12
LETTER TO EDITOR	14
STR8UP	16
BUILD	38
PETS N PWCS	78
FITNESS	78
TECH	88
FUTURE THREATS	83
GEAR GIVEAWAY	86

EAST COAST WATERCROSS SERIES COLLABORATES WITH DEFENSE CONTRACTORS 18

ECW featured full lines and cutting-edge technology testing.

WOMEN'S WAVEBLASTER SPARKS INTEREST AT SPARKS 28

Eight women competed in first Women's WaveBlaster class Wild West Watercross.

CROTIAN JET SKI ODYSSEY 24

Welcome to #virevent a gathering for rec riders across Europe.

SUMMER SLAM 26

Hot Products Best of the West Nationals racing on the Colorado River.

FOURTH ANNUAL KENTUCKY PWC RIDERS WATERFALL EXTRAVAGANZA 32

What an awe-inspiring sight: a hundred yards of endless waterfalls.

EVENT RECAP: 2024 SGT GREAT LAKES WATERCROSS TOUR 36

Top racers competed on the mighty Mississippi.

JUNIOR RACER'S JET SKI JOURNEY POLAND 38

Racing was only part of Jettribe's Vo family's adventure.

1994 KAWASAKI SC650 WOUNDED WARRIOR PROJECT/ SUPER CHICKEN 46

Skilled to raise awareness and help support WWP.

NEW VENUES LIVESTREAMING JETTRIBE NAUTIWATER RACE SERIES 48

Jettribe Series of Champions set record with 2,200 entries.

THE GREAT BAHAMAS CHALLENGE 52

Like minded individuals come together for ride of a lifetime.

SPRINT BOAT TRACK 56

Westcoast Surf Riders dazzled at American Sprint Boat Race halftime show.

RACING RETURNS TO THE GOLD COAST 58

Competitors from around the world participated in Australian Watercross.

WOW-MOLLY PRO WATERCROSS TRIPLE CROWN FINALE 68

Series stop at Tugaloo State Park, Lavonia, Georgia drew top athletes.

POKER, PRIZES, AND COMMUNITY SPIRIT 62

Second Annual Nauti Girl Crew Poker Run exudes teamwork and fun.

WILD WEST WATERCROSS BRINGS THE HEAT 66

Wild West Watercross brings change and innovation to race scene.

AQUABIKE'S GP OF ITALY REGIONE SARDEGNA 74

Olbia, 'city of happiness' challenging yet welcoming venue.

ARIZONA PWC ENTHUSIASTS' RIDE TO HOOPER DAM 76

Glass water and beautiful scenery were breathtaking.



INTRODUCING THE ALL-NEW
JETBLASTER
WAVERUNNER® SERIES



RIDEFULLBLAST.COM

Professional rider with advanced skills depicted in a closed area. This document contains many of Yamaha's valuable trademarks. It may also contain trademarks belonging to other companies. Any references to other companies or their products are for identification purposes only, and are not intended to be an endorsement. Follow instructional materials and obey all laws. Ride responsibly, wearing protective apparel and USCG-approved personal flotation device. Always ride within your capabilities, allowing time and distance for maneuvering, and respect others around you. Never drink and ride. WaveRunner® is a Yamaha brand personal watercraft and not a generic term. ©2024 Yamaha Motor Corporation, U.S.A. All rights reserved.

PRO RIDER™

WATERCRAFT MAGAZINE

SEPTEMBER / OCTOBER CONTRIBUTORS



Annie Donovan Cassel
Pro Racer Event Coordinator



Arek Rejs
Arek Rejs Photography



Brian Baker
Digital Creator



Charles Guinchard
Charles Guinchard Photography

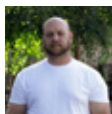

Cory Eads
Cory Eads Photography



Craig Milne
Zoomed Images



Dan Lindgren
President Westcoast Surf Riders

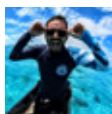

Danni Mitti
Bahamas Challenge Admin

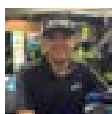

Dave Bamdas
President Riva Racing



Dawn Dawson
Pro Sports Announcer & President Reflections Advertising



Dieter Quaghebeur
Braapshots



Duv Cardenas
Pro Racer & Sponsor Women WaveBlaster Series



Dylan Foureau
Money Pit Creations



Greg Cobb
Gregory Cobb Photography



Haulin' Harry Goatcher
Team Goatcher

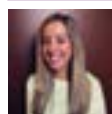

Jaymi Bohat
Great Lakes Watercross Tour Promoter



Jim Flynn
J James Photography



Josh Klem
Owner Founder MotoOption and FactoryFade

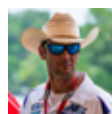

Justin Smith
Race Director Jettribe NautiWater Racing



Ken Gallagher
Ken Gallagher Photography



Kenny Wong
KDW Sports Photos



Kyla Desrosiers
Pro Racer Fitness Trainer Jet Pump Fit



Mike Young
Pro Sports Announcer President Surf and Turf Promotions



Monte Hughes
CEO Monster Watercraft



Rain Porter
121 Photo

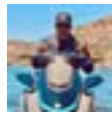

Randy Lovato
Founder AriZona PWC Enthusiast

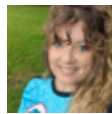

Renee Hill
Founder Nauti Girl Crew



Rick Powell
Ric Pow Photography



Ross Wallach
President RPM Racing Enterprises



Shawn Dudek
Owner East Coast Watercross Tour



Simon Palfrader
Photographer

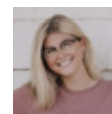

Skylar Mack Ramjeet
Skylar Mack Ramjeet Photography



Theresa Galdony
President Color America



Tyler Reardon
Tyler Reardon Photography



Zee Khan
Zee Picture Perfect



Peter Ratti
Technical Advisor

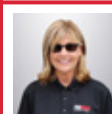

Cathy Ratti
Subscriptions & Distribution



Bailey Vasquez
Graphic Design



Sadie Mir
Intern

191 WILSON ROAD • JACKSON, GA 30233
WWW.PRORIDERMAG.COM

PUBLISHER & EDITORIAL DIRECTOR:
Michael Ratti
michael@proridermag.com
Australia +61 426 771 331

SUBSCRIPTIONS & DISTRIBUTION:
Cathy Ratti
cathy@proridermag.com
USA +770.883.8356

GRAPHIC DESIGN:
Bailey Vasquez - Sutherland Printing

INTERN:
Sadie Mir

Subscription Services:

Email cathy@proridermag.com, call 770-883-8356, or write to Pro Rider Watercraft Magazine, 191 Wilson Road, Jackson, GA 30233. Please include name, address, and phone number on any inquiries. For change of address three weeks' notice is required.

Note:

Much of the action depicted in this publication is potentially dangerous. Virtually all the riders seen in our photos are experienced experts or professionals. Do not attempt to duplicate any stunts that are beyond your own capabilities. Always wear appropriate safety gear.

We welcome your company and industry news. Please include digital photos with your press release and send the information to michael@proridermag.com or cathy@proridermag.com. We cannot be responsible for unsolicited product samples. The publisher does not assume liability for products or services advertised herein.

Pro Rider Watercraft Magazine is published bimonthly by Michael Ratti, LLC. All content is copyrighted by Pro Rider Watercraft Magazine and reproduction in whole or in part without written permission is prohibited.

Copyright 2024
Pro Rider Watercraft Magazine
DESIGNED AND PRINTED IN THE USA

Printed by Sutherland Printing



GREENHULK

PWC PERFORMANCE

GREENHULK
PWC PERFORMANCE

A 4-TEC
PERFORMANCE, LLC
COMPANY



GREENHULK.NET
PWC PERFORMANCE FORUM



DISCOUNTED PRODUCTS FROM:



SEARCH ALL PARTS FOR YOUR SKI BY MAKE AND MODEL 🔍

WE SHIP
WORLDWIDE

USPS UPS FEDEX DHL



USE DISCOUNT CODE
greenhulk

NOW OFFERING
FACTORY
REPLACEMENT
PARTS



WWW.GREENHULK.NET

WWW.4-TECPERFORMANCE.COM

@GREENHULKPWCPERFORMANCESTORE

SEPTEMBER/OCTOBER 2024

The 2024 September/October cover shot goes to Yamaha's all-new JetBlaster WaveRunner Series®, an exhilarating addition designed for riders seeking a lightweight, agile, and compact watercraft. The JetBlaster Series offers an exciting ride at an affordable price. Measuring 116 inches in length, 44.5 inches in width, and weighing as light as 529 lbs., the JetBlaster Series is the most compact-sized sit-down WaveRunners® available. The series includes four models, each designed to provide a playful and enjoyable riding experience!



WWW.FACEBOOK.COM/PRORIDERMAG

1. Best magazine rack ever! Showtime Freestyle Showroom @lukestocks
2. Kris VanWie, Jr. representing at East Coast Watercross tour stop Watkins Glen, New York
3. Feel the energy of the Tapajos Expedition @091_jetski
4. Charlie Adams drip drying at American Jet Sport Assoc.
5. Spotted on the ceiling of Hog's Breath Café Surfer's Paradise, Australia

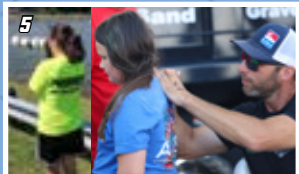
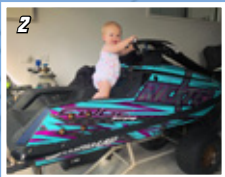

PRORIDERGRAMS

1. @salty_paint flooded firepit = mini jet ski pond NSW Australia
2. #nextgenfreestyle #thiscouldgetexpensive @frailz199
3. @nautigirlcrew #giagofast
4. #bustedinAZ @askrandylovato
5. @actionshotsmx @ajsa_racing



- 88 ISSUES OF PRO RIDER
- RAMPS
- 900CC
- CUSTOM TURF JOBS
- DOUBLE FLIPS
- HIGH SPEED RUNS
- FISHING

- FLIP LEVERS
- REBUILDS
- NO WAKE ZONES
- ELECTRIC JET SKIS
- ANALOG DISPLAYS
- CROCS WITH SOCKS
- RENTAL FAIL VIDEOS

BLOWSION 4-STROKE YAMAHA SUPERJET STEERING ENHANCEMENT COMPONENTS

BLOWSION STEERING CABLE BRACKET

PART # 03-04-199

Cable bracket that creates a linear steering ratio when used with Blowsion HD Steering Cable

UNIVERSAL OVP STEERING SYSTEM

OVP Universal system's adjustable arm allows the rider to dial in preferred steering quickness

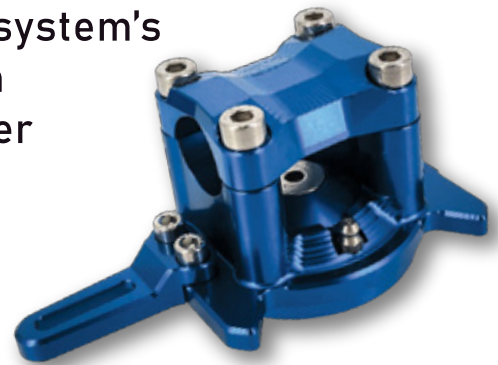

BLOWSION SUPERJET HEAVY DUTY STEERING CABLE

PART # 02-05-302

Up to 35% more steering cable travel. Increases steering nozzle travel for sharper turns



PR EDITOR'S LETTER

PRO RIDER

CELEBRATES 80 ISSUES!

Photos: Ritchie Gregg, Josh Brailey,
Tegan Kamp

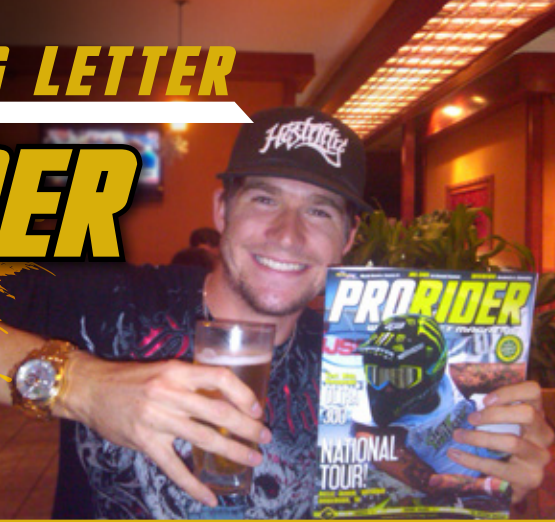

The past six weeks have been busy and eventful. We kicked things off with the Offshore Vodka launch party, hosted by Jet Pack Events at the renowned Cali Beach Club in Gold Coast, Queensland. Soon after, we returned to Cali Beach Club in the early morning, this time in partnership with The Today Show and Jet Pack Events, to support the charity Fight MND. Next, we were at the Sanctuary Cove Intercontinental Resort man-made beach pool for a Queensland tourism activation.

Soon after, I packed my gear and headed to Nha Trang, Vietnam. There, I teamed up with the H2O Events team and the local Vinpearl Waterworld crew for "Rise Of The Ocean Princess," a live-action stunt show on the open ocean at the Vinpearl Harbour. With its impressive effects and local talent, this production has been one of my most rewarding and culturally enriching experiences.

Reflecting on this milestone — 80 issues of Pro Rider Watercraft Magazine — it's incredible to see how a simple high school dream has become a reality. What started with jet skiing and spending time with my father, friends and family has birthed Pro Rider, travelling the world, celebrating all aspects of the sport and becoming a trusted global news source for everything personal watercraft. I'd like to personally thank my mom Cathy Ratti, and my dad Peter Ratti for their guidance, encouragement and everything they have done and continue to do. A heartfelt thanks also goes to my wife, Siana, and my children, Aaliyah and Romeo, for their steadfast support.

With over 170,000 copies printed and millions reached, we're marking 80 issues and 14 years in business. Looking ahead, we plan to enhance our digital offerings, boost industry support, and introduce new products and gear.

Help us celebrate by spreading the word, subscribing, and supporting our advertisers. Pro Rider is truly a magazine for the community, and it's time to celebrate! As the great engine builder Paul Lher would say, "Ski ya' on the water!" **PR**

 Michael Ratti and
the Pro Rider Team

Instagram: @michael_ratti

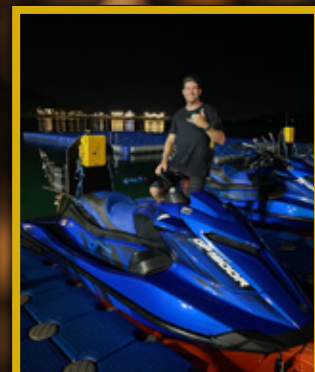
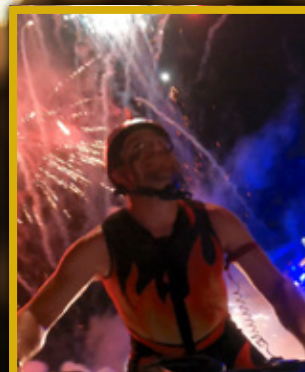
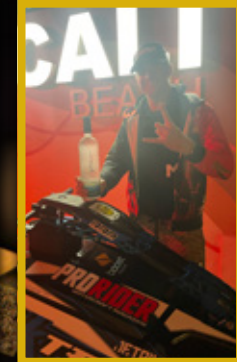
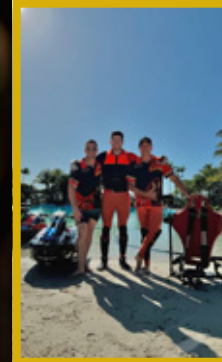
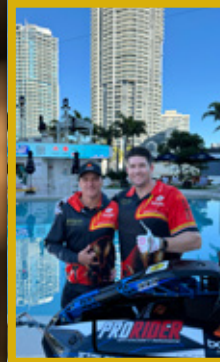



JetPILOT

LIMITED EDITION



STARS AND STRIPES



RACE SUIT

ONLY ON JETPILOT.COM

jetpilot.com [jetpilotusa](https://www.instagram.com/jetpilotusa)

Tory Snyder
Professional PWC Racer

JetPILOT

Motor Oils & Additives.
Made in Germany.
Made for you.

Sam Nehme
TRUE STORIES
TRUE BENEFITS. TRUE PASSION.

LIQUI
MOLY
MARINE



I use it!

“I have won multiple National & World Championships on my Jet Skis as well as have had hundreds of hours on my personal performance boat for enjoyment! The common denominator in all of this is LIQUI MOLY Marine Products! I win on the race track and at the sandbar with flawless & reliable performance which gives me piece of mind!”

Sam Nehme
President
Broward Motorsports



See the whole success story: www.iuseit.us



Find the right oil!



Newsletter



Teamstore

#iuseit

For further information or technical support
please call 1-888-MOLYOIL (665-9645)



WE HAVE AN **AMAZING SELECTION** OF PARTS AND ACCESSORIES IN STOCK AND READY TO GO.



GREG BROCK
 PRO FREESTYLE MULTI CHAMPION;
 LIQUID X-FREESTYLE TOUR PERFORMER;
 FOUNDER FREESTYLE FACTORY



PHOTO BY FOUR F MEDIA

NEED FOR SPEED?
 DROP BY THE SHOP AND LET'S TALK!

Freestyle Factory



TEAM HAS BEEN HARD AT WORK BUILDING SOME **AMAZING WATERCRAFT.**



FREESTYLE FACTORY
 is proud to support **Sadie Mir**
 at this year's World Finals.



MAKE FREESTYLE FACTORY A DESTINATION STOP. WE ARE ON THE WATER.

COME BY LAND OR BY BOAT. DOCK AND SHOP!

FREESTYLEFACTORY.COM

25276 West Grass Lake RD Antioch, Illinois 60002 312-925-4005



MOTOPTION LAUNCHES NEW SERVICES THROUGH FACTORY FADE

www.factoryfade.com  /factoryfadeusa  @factoryfadeusa



PRO RIDER: What inspired you to incorporate FactoryFade into your entrepreneurial endeavors?

JOSH KLEM: We built MotoOption by handling everything in-house — graphic design, marketing, apparel printing, and custom products. This hands-on approach drew attention, leading us to assist other companies with branding. After expanding our team and equipment, we created FactoryFade to offer custom branding solutions. With 19 years of experience, we provide a one-stop shop for companies and race teams, delivering high-quality branded products rooted in motorsports DNA.

PR: Please describe the focus of FactoryFade.

JK: Our main goal is to help companies and race teams highlight their brands and sponsors. We specialize in graphic design, custom canopies, wind flags, signs, banners, and sublimated team wear. FactoryFade streamlines the branding process with a single point of contact, saving you time and hassle. Whether you have print-ready artwork or just an idea, we offer personalized service to create a comprehensive brand identity package, including event setups and trade show booths.

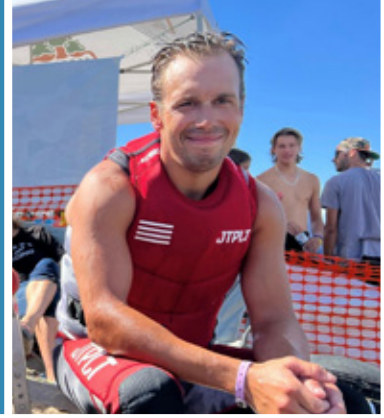

TYRON MOTZOURIS
MARCH 18, 1987–AUGUST 29, 2024

As we went to press, we were deeply saddened to learn of the passing of Pro Ski Multi-Champion and renowned hull designer Tyron Motzouris, younger brother of Dustin Motzouris. Tyron sustained a severe head injury during the first lap of Pro Ski Moto 1 at the 2022 World Finals following a collision with another racer. We send our deepest condolences to his family, friends, and the entire watercraft community. Pro Rider will honor Tyron's legacy with a dedicated feature in our year-end edition.



NIAGARA RIVER RIDING

Submitted by: Ken Rozler, *Member WNY Jetski*

We usually ride on the upper Niagara River and Lake Erie, with a smaller part of our group exploring NY's Finger Lakes and the lower Niagara River. We frequently join other jet ski groups to find new spots to ride and camp. Recently, I power washed the rustic launch docks at Niawanda Park in Tonawanda, NY, to clear the 'goose grease' before our group arrived. That day, we had a fantastic group of riders, toured around Grand Island, enjoyed a picnic, and took friends visiting from NC wakeboarding off the back of our jet skis.



PHOTO CONTEST WINNER

Congratulations to Polina Antipova, Odessa, FL, winner of the Jul-Aug 2024 Photo Contest sponsored by Bomber Eyewear! Polina's winning photo was taken at Anclote Island on Florida's Gulf Coast at sunset. She shared that her family — her husband, their 10-year-old, and herself — often visits Anclote or Three Rooker Island, and occasionally jetskis to Alligator Reef Lighthouse and Weeki Wachee Springs. Polina will receive a Bomber prize package, including Tiger Green Mirror Glasses, a hat, and a beach towel.



WELCOME ABOARD BABY GADDIS

Congratulations to Pro Rider Tech Writer Greg Gaddis aka Greenhulk, Jr. and Kylie Henson on the birth of their precious daughter Eleanor "Ellie" Mae Gaddis born July 20, 2024. Don't blink, she'll be wrenching and riding before you know it.



CREATIVE SUMMER SURPRISE FOR TEEN JET SKI CREW

Submitted by: Jaime Lovely Oxford, Michigan

This summer, my husband was scrolling through social media and stumbled upon a post on "Everything Stand Up Jetski" where someone thanked Walmart for their new swimsuit. That gave me an idea to surprise our son Luke with one. Then I thought, why not make it even more fun? I texted the moms of Luke's five buddies who come over to ride and asked if they wanted to join in on the surprise. They were all in! We coordinated to get the boys together, making sure they brought their skis, all while keeping the surprise a secret. The boys tried to guess what it could be — Luke was convinced his dad had scored a fleet of bumper boats. Somehow, it worked out perfectly — none of them had to work, they were all in town, and they could all come over. I put the swimsuits in gift bags and had them open them at the same time. The boys were cracking up when they saw the suits — they couldn't believe we found bathing suits with T-Rexes riding stand-up jet skis!

They quickly changed into their new suits and hit the water, grinning from ear to ear. With Michigan's Brave the Wave on hold this summer, matching T-Rex jet ski suits will have to do!



Pictured L-R: Jacob Ball, Colin Blakely, Hayden Stapp, Sawyer Hope, Ethan Kussner and Luke Lovely.



INAUGURAL PERSONAL WATERCRAFT OWNERS CONVENTION

IJSBA is excited to announce the inaugural Personal Watercraft Owners Convention at the 2024 SBT WGP-1 World Finals in Lake Havasu, Arizona. This annual event allows enthusiasts to connect with key industry figures and influencers who shaped the sport. Workshops and presentations will demystify PWC technology, covering topics like impellers, ECU reprogramming, and the history of watercraft. The convention is free, with limited special access for advance registrants. Scheduled during Pro weekend October 12-13, the event features discussion groups on General PWC, Vintage Ski, Vintage X2, and Sea-Doo X4/XPL. Stay tuned to IJSBA and GreenHulk.net for more details!

"We at Greenhulk are immensely proud to be the title sponsor of the first annual IJSBA Personal Watercraft Owners' and Enthusiasts' Convention. This event represents a significant milestone for the community, and we're thrilled to support and celebrate the passion and dedication of personal watercraft enthusiasts."

— Jerry, Greg and Alex Gaddis



Photos: Captain Jocassee

DEAR PRO RIDER WATERCRAFT MAGAZINE,

I've been into personal watercraft for as long as I can remember. There's nothing like the thrill of riding and seeing people light up with joy on the water. This past year riding with Jet Rider Nation and Kentucky PWC Riders has been a blast, with amazing rides and great camaraderie. My go-to spots include Lakes Jocassee and Keowee in South Carolina — my favorite places to ride. I've enjoyed organizing and leading Jet Rider Nation South Carolina rides and look forward to more great rides in 2025.

I came across Pro Rider Watercraft Magazine through the sport and decided to subscribe. It's packed with awesome features and incredible photos that make it a magazine I keep coming back to.

Keep up the great work!

Mason Piazza

Admin. Jet Rider Nation South Carolina
Seneca, South Carolina



Photo: Cory Eads 





Z PHOTO: Craig Milne



UNLEASH YOUR AQUATIC ADVENTURE WITH **REBEL OPTICS' DEFIANT PRO GOGGLES**

As the sun dances on the water's surface, and the roar of your engine propels you across the waves, there's no room for compromise when it comes to your vision. The Defiant Pro Goggles by Rebel Optics is the ultimate eyewear designed to dominate the world of PWC.

ENGINEERED FOR PERFORMANCE • UNPARALLELED CLARITY AND PROTECTION • COMFORT THAT LASTS

"REBEL OPTICS GOGGLES ARE LIKE NOTHING I'VE EVER TRIED BEFORE.

After my first moto with them, I was stunned by the quality. They never fog or scratch, unlike many big-name brand goggles. They are amazing people to work with and I can't wait to introduce them to the rest of the world!"

Sadie Mir, Professional Jetski Racer
2x National Champion | 2x Women's Regional Champion



REBEL OPTICS
REBELOPTICSLLC.COM

@REBELOPTICSLLC

JOIN THE REVOLUTION

Visit our website to learn more about our high-performance eyewear designed to enhance your adventures on and off the water.



WAKE STRAP

is the ultimate safety and freedom strap for passengers riding on the back of any PWC!

COMES IN 4 COLORS

The Wake Strap has a 2-inch soft nylon webbing strap and a 2-inch heavy-duty adjustable buckle. The handle is made with a roll-bar grab handgrip providing a comfortable hold.

- Fits most Jet Skis, WaveRunners, and Sea-Doos
- Handsewn with UV protectant thread for long-lasting durability from the sun
- Soft nylon strap will not cause friction to the seat

Watch how easy installation is on our Instagram page!

"THE WAKE STRAP PROVIDES A SAFE AND NATURAL WAY TO HOLD ON WITHOUT INTERRUPTING THE DRIVER."
KEVIN YOUNTS, INVENTOR OF WAKE STRAP

678.920.0948
katyounts@gmail.com

WWW.WAKESTRAP.COM

wake.strap
PWC Wake Strap



"FIFTH TIME WAS THE CHARM. GOING THROUGH MY MIND WAS PURE DETERMINATION TO LAND THE FLIP, NO MATTER THE COST, AS YOU COULD TELL BY THE BAIL PHOTOS."

JAKE LUCKEY,
WINNER 2024 SCX FIRST TIME FLIP CONTEST



JAKE LUCKEY

HOMETOWN: MOLENDINAR, GOLD COAST, AUSTRALIA

PHOTOGRAPHER: CHLOE MOTZOURIS @SHOT_BY_CHLOE

LOCATION: SUNSHINE COAST AUSTRALIA SCX 2024



ST. PETERSBURG POWERBOAT GRAND PRIX

2024



PRESENTED BY:
ST. PETE
CLEARWATER



OCTOBER 18-20 • ST. PETE PIER

FREE TO WATCH • FAMILY FRIENDLY • RACING STARTS AT 9AM

MORE INFO AT: PIAQUAX.COM



SCAN HERE FOR
VIP TICKETS





TESTING NEW TECH:

SBT EAST COAST WATERCROSS SERIES COLLABORATES WITH DEFENSE CONTRACTORS AND ENGINEERS

By: Shawn Dudek, *Owner East Coast Watercross*
Photos Sylvan Beach: Brian Baker | Photos Plattsburgh: Tyler Reardon

Sylvan Beach, NY, hosted rounds 3 and 4 of the 2024 East Coast Watercross Series. In Sylvan Beach, after setting up the racetrack with 129 entries and 68 motos, we collaborated with L3 Harris, a major U.S. defense contractor, to test new military radio technology intended for drone boats in warzones. Our marshals and course setters wore vests equipped with these radios, providing real-world testing on the water. This partnership will continue throughout the season, helping L3 Harris gather the data needed to move the technology into production, with the goal of saving lives.

Additionally, engineers from @mylaps demoed their new GPS transponder technology, which could potentially replace hand scoring in racing. The system was used to fully layout our track and time splits, proving extremely useful. We equipped two of the most challenging classes to score — Pro/Am Vintage X2 Open and Am/Nov 1100 Limited — with demo units. Throughout the weekend, we monitored lap times, positions, speed, and distance, collecting vast amounts of data. This new GPS-based transponder system looks promising and could elevate the sport to match the technological standards of motocross and snowcross, which transitioned to transponders in the mid-2000s.





**MORE INFORMATION AND FULL RESULTS:
[HTTPS://EASTCOASTWATERCROSS.COM/](https://eastcoastwatercross.com/)**

Round 4 in Sylvan started with decent weather, but by mid-afternoon, dark clouds and 30–40 mph winds turned it into chaos. We evacuated our tower, moved to shore, and had to adapt quickly as 6–7' waves wiped out most of our course. Despite the conditions, we completed all 68 motos, and racers had a blast riding the massive swells!

Rounds 5 and 6 of the 2024 SBT East Coast Watercross Tour took place at Plattsburgh City Beach, Plattsburgh, NY. Saturday's races went off without a hitch under perfect weather, followed by an awards ceremony with stunning lake and mountain views. Sunday started strong, but lightning forced us to pause racing. Winds picked up, making for exciting conditions, but 20 minutes into the race, another storm cell cut the day short. Despite some broken ez ups, it was a great weekend of racing in the Adirondacks, and we'll be back next year! **PR**



Scan and watch amazing drone content from ECW Plattsburgh, NY

Filmed by Dylan Forneau Money Pit Creations



Women's WaveBlaster

Sparks Interest at Sparks

By: Duv Holland Cardenas
 Photos: Chris Liu; Duv Cardenas;
 Cliff Cassel; Kenny Wong



July 21–22 in Sparks, Nevada, eight adventurous women competed in the inaugural Women's WaveBlaster class as part of Wild West Watercross's race series four-moto format, with two motos on Saturday, two on Sunday scored together for the overall. The class featured Waveblaster 1 hulls with builds limited to the rules of Sport Spec Waveblasters.

The idea emerged organically when some women with WaveBlasters wanted to race but preferred not to compete in the highly competitive Sport Spec class with the guys. Wild West embraced the idea and introduced a Women's WaveBlaster class for the final round of their 2024 NorCal and Nevada tour.

Saturday morning, the women lined up to race, split between those with WaveBlasters at home but no racing experience and those who raced before but were on borrowed WaveBlasters, all beginners at racing or beginners on the WaveBlaster platform. Understandably, the first moto was raced cautiously as everyone adjusted to the ski and competition.

As the intensity ramped up, confidence soared with each moto, and everyone was determined to win! Watching the racers' progress over the weekend was incredible. All but one completed all four motos and each earned a \$100 payout for their efforts.* The racer who missed some motos battled hard to fix her ski but could not get it running in time.

The placings varied considerably, showing it was anybody's game and consistency was key. Podium finishers, first through third respectively, were Arianna Chen, Lainey Garrett, and Jamie Que.

The class was a resounding success, with participants eager to return next year and many others looking to join in 2025.

Interest has been sparked at Sparks, and this exciting class is sure to explode next year!

WOMEN'S BLASTER STOCK RESULTS

1. #86 Arianna Chen
2. #114 Lainey Garrett
3. #328 Jamie Que
4. #44 Juliana Meyer
5. #70 Annie Cassel
6. #407 Rachel Chattin
7. #492 Jennifer Bliss
8. #22 Trina Peckenharn

**Editor's note: The payout for the Women's Blaster Class was made possible by the generosity of Ms. Cardenas' sponsorship. PR*



MAKE WAVES

// NEOPRENE FLOATATION VEST

FLY
RACING

24
WTR

STRETCH
MATERIAL
CONSTRUCTION

FLYRACING.COM



WORX RACING ACQUIRES DASA WATERCRAFT



The acquisition of Dasa Watercraft was motivated by our shared commitment to excellence and innovation in the watercraft industry. Dasa's renowned reputation for high-performance products and its strong customer base perfectly align with Worx Racing Components' vision for growth and leadership in this field. We finalized the acquisition in April 2024, marking a new chapter for both companies.



Our vision is to merge the strengths of both Worx Racing Components and Dasa Watercraft to create unparalleled products that push the boundaries of watercraft performance. We aim to leverage Dasa's legacy by investing in research and development, enhancing our product lineup, and expanding our market presence. We proudly sponsor several talented riders, including Mark Gomez, Abraham Hochstrasser and Coy Curtis, who embody the spirit and dedication of our brand and continue to achieve remarkable success in competitions.

Under our leadership, customers can anticipate exciting innovations such as advanced engine technologies and enhanced customization options. We are committed to maintaining Dasa's high standards while introducing cutting-edge solutions that meet the evolving needs of our customers. Our focus is on delivering products that provide exceptional performance and reliability.





Having spent years in the watercraft industry, Worx will bring a deep understanding of the market dynamics and customer expectations with Dasa Watercraft. Kyle Kennedy's extensive experience in product development will be instrumental in driving innovation and growth. Through this acquisition, we aim to enhance the watercraft community by offering superior products and supporting initiatives that promote safe and enjoyable water sports. Our goal is to inspire the next generation of enthusiasts and professionals.

PROUDLY DESIGNED, BUILT, AND DEVELOPED IN THE USA

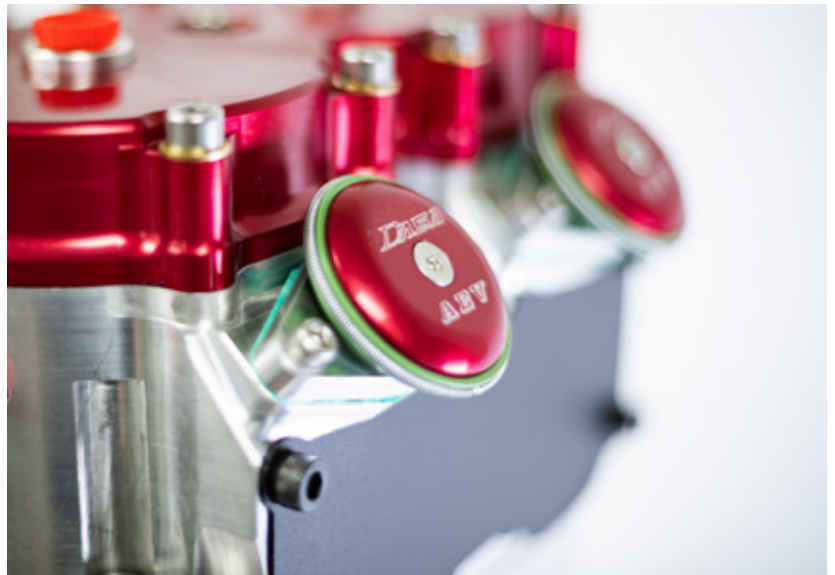

We are very proud to uphold the tradition of excellence by ensuring that Dasa Watercraft will continue to be designed, developed, and manufactured in the USA. This commitment not only honors the legacy of Dasa but also supports local industry and innovation, reflecting our dedication to quality and craftsmanship that our customers have come to trust and expect.



For any enquiries please contact:
info@worxracingusa.com
or
info@worx.com.au

WORX
RACING COMPONENTS

#VIREVENT 2024: A JET SKI ODYSSEY IN CROATIA

By: Matija Bede | Photos: Jet Ski HR



On the sun-kissed shores of the island of Vir, Croatia the roar of jet skis signaled the start of the most thrilling event of the year. Welcome to #virevent 2024, an annual gathering that has become a beacon for recreational riders across Europe. What began four years ago as a local celebration organized by JET SKI HR and the Jet Ski Otok Vir Facebook group has grown into a spectacular showcase of watercraft and camaraderie.

This year's event, the largest yet, brought together 55 jet skis and 87 passionate participants. The 100-kilometer (approximately 62-mile) route was a mesmerizing journey through Croatia's coastal beauty, blending adventure with scenic wonder. Riders ventured through ancient submarine tunnels and navigated the crystalline waters between four stunning Croatian islands: Molat, Sestrunj, Dugi Otok, and Olib.

Olib's sandy beach was perfect for socializing as riders exchanged stories. The event was not just about the thrill of the ride; it was about building community and celebrating shared passions.

This year's ride marked a significant milestone, showcasing its evolution into an international European event. Participants came from Austria, Germany, Italy, Hungary, Bosnia and Herzegovina, Serbia, Sweden, the Czech Republic, Slovakia, and, of course, Croatia.

The event is organized by JET SKI HR, with support from co-organizers Jet Ski Otok Vir, Jet Ski Slo, Luxury Marine (Sea-Doo distributor), and Moto Plus Ikica (Yamaha distributor).

Founded in 2019 JET SKI HR has grown to 6,000 members worldwide. Its mission is to strengthen the European recreational riding community, promote jet skiing as both a sport and a hobby, and improve the public perception of jet ski riders. In an era where negative stereotypes can overshadow the sport, JET SKI HR is committed to highlighting the positive aspects of jet skiing and encouraging responsible riding.

As the sun sets on #virevent 2024, the roar of the jet skis fades, but the memories and friendships forged will continue to resonate until next year, when the excitement of the open water calls bringing together old friends and new in the ever-growing celebration of jet skiing. **PR**



FOR THOSE INTERESTED IN JOINING THE GROWING JET SKI COMMUNITY OR LEARNING MORE ABOUT JET SKI HR, CONNECT WITH THEM THROUGH THEIR FACEBOOK GROUP AND INSTAGRAM @JETSKINR.

We are excited to announce we have **teamed up with Hankster's Motorsports** and are now offering **NEW Yamaha Super Jets** with varying stages of mods.

***NEW 2024 Super Jet Stage One Handling Mods**

*Financing and shipping available

- RCJS BILLET STEER SYSTEM
- RCJS BILLET JET PUMP INTAKE GRATE
- RCJS BILLET REAR BLADE SPONSONS
- ADJUSTED THE TPS TO TUNE OUT LOW SPEED ENGINE HESITATION AND BOG
- JETTRIM MAT SET FOR ADDED COMFORT AND CONTROL



Watch Watcon Watercraft Talk on YouTube



211 GLEN ST. JANESVILLE, WI 53545

• 608-743-1305

• 9AM TO 5PM CST M-F



PHOTO COURTESY OF SEAN LUNG

PHOTOS: KENNETH WONG

INTRODUCING WRT SPARK PLUG CASES

3D printed in Central California with UV-resistant PETG plastic. Available in black, gray, red, orange, purple, blue, pink, and green, these cases come in sizes for two, three, four, or eight plugs. Ideal for both older and newer skis, they offer flexibility for dedicated or multi-ski use.

For more details and to order, follow **WININGER RACING TEAM** on Instagram, Facebook, and YouTube!



FOR ALL RESULTS AND INFORMATION PLEASE VISIT
WWW.RPMRACINGENT.COM



SUMMER SLAM

By: Ross Wallach, *President RPM Racing Enterprises*

Rounds 8 & 9 of The Blue Water Resort & Casino — Hot Products Best of the West Series Presented by Jettrim, Impros, Bomber Eyewear, Sandhopper Industries, Jettribe, Works H2O, 95.7 River Rat Radio, Oakley, Kawasaki, SBT, JC Racing, 3D Design Concepts, Ultimate Watercraft, Monster Watercraft, Throttle Junkie News, The Watercraft Journal, West Coast Watercraft Club & Pro Rider Watercraft Magazine

The Blue Water Resort and Casino in Parker, Arizona again hosted the Hot Products Best of the West Series IJSBA Western Nationals — Summer Slam. The usually calm Colorado River became the stage for some of the nation's fastest, most intense closed-course personal watercraft racing. With temperatures soaring to 113 degrees, "hot" was the word of the weekend!

This IJSBA World Finals qualifier brought together seasoned racers and promising newcomers on a newly designed track by Todd "Sarge" Young. With a record post-COVID turnout of 160 entrants and 84 motos, the event ran smoothly with zero jump starts, thanks to the efficient Sandhopper start system. From Juniors to Pro and Expert Ski GP, impressive battles unfolded across all classes. **PR**

LIKE US ON FACEBOOK, INSTAGRAM AND X
 HOT PRODUCTS BEST OF THE WEST SERIES PRESENTED BY JETTRIM





PREPARE FOR THE ULTIMATE ADRENALINE RUSH!

Embark on a paradise getaway with **SAK PASE RENTAL** at Peanut Island on Florida's east coast. Dive into the mesmerizing splendor of turquoise waters and **CREATE UNFORGETTABLE MEMORIES!**



@sakpasrental Sak Pase Rental



561-303-0417
sakpasrental@yahoo.com

WWW.SAKPASERENTAL.COM



EZ-SKI
Jet Ski Hitch-Haulers

#1 JET SKI HITCH-HAULER IN THE INDUSTRY
10 YEARS RUNNING

NEW!
INTRODUCING THE EZ-SKI® MINI TOTE HAULER

STRONGEST
MOST AFFORDABLE
MOST AVAILABLE
JET SKI HITCH HAULER
ON THE PLANET

NEW!
EZ-SKI® FZ FUEL TRAY
THE 'EZ' WAY TO TRANSPORT 5 GALLON FUEL JUGS

DON'T SETTLE for a knockoff or copy, **INSIST** on the superior quality and reliability of **Ez-Ski®!**

TEXT OR CALL
www.ezskifab.com | 928.846.7647



ACTION HORIZONS

NEED FOR SPEED

Get in on the action!



@ACTION_HORIZONS_STUNTS



SCAN TO SEE MORE OF THE ACTION

771 IND

REP LIFE'S RIDE

HATS - T-SHIRTS - TANKS - SWEATS
STICKERS - & MORE

REP LIFE'S RIDE

CHECK US OUT ON:

Model: Rain Porter
Photo: KDW Photos
771industries@gmail.com

WORLD'S FASTEST INTERCOOLERS

FIZZLE Y1000 INTERCOOLER

FOR YAMAHA SVHO/SHO

POWERING THE WORLD'S FASTEST PWC **142 MPH**

FIZZLE SUPERCooler

FOR SEA-DOO 325 • 300 • 230

FIZZLE RACING

CONTACT US
FIZZLERACING.COM
 FIZZLERACING

ACTION

KAWASAKI YAMAHA

BRADENTON, FL.

PHOTO: E. DAVIS PHOTOGRAPHY

PHOTO: KEN GALLAGHER

PHOTO: RIC POW PHOTOGRAPHY

- VISIT US TODAY -

RACING AND FREESTYLING SINCE 1988

ACTION TEAM MEMBER MIKE KLIPPENSTEIN—WHETHER LAND OR WATER, HE'S GOTTA' BE RACING!

2705 1ST ST., BRADENTON, FL 34208 | 941.745.9521 | ACTIONKAWASAKIYAMAHA.COM

A Work of Art!

The Ultimate X2 Project with Iconic Paint Job

By: 'Haulin' Harry Goatcher Team Goatcher Racing
Photos: Greg Cobb, Gregory Cobb Photography



Watch tell all video

Goatcher describes project in detail



This adventure began a year and a half ago with a call from dear friend and longtime jet ski fan, Mark Bove, aka "the Pasta Man." He loved my R&R JetTech 550s with their amazing paint jobs and asked if I could replicate the "fruit stripe" design on a vintage X2 which had never been done but he didn't budge.

First call was to legendary painter Don Serrano, motorsports icon known for phenomenal work. Jerry Ham of M&M Marine had a cream puff vintage X2 ready for the right buyer.

A local mechanic stripped and prepped it for paint. Craig Campbell, X2 advocate, fibreglassed the holes, relocated the stock exhaust outlet, and installed front sponsons.

Time to kick off the motor build with Monte Hughes of Montster Watercraft, who did a fantastic job on my wife's X2 mod. He sent the crank and cylinder to Christopher Steenbock of C57, and the project began! Mark wanted "10/10 bling," so Monte had all parts epoxy-painted and chrome-polished.

We deal a lot with Jared Martin, Wax Racing of Australia and purchased his new complete exhaust system. Charlie Sims directed us to David Stewart of Leading Edge Impellers who crafted a totally custom impeller.

After six months of magic, Serrano finished this one-of-a-kind work of art. Good friend and sponsor Joel Jaye of Air Ads Worldwide transported the ski wrapped in blankets to protect it on the roadtrip as we met in Bakersfield, CA. Frank Walsh and fantastic staff at Jettrim used the last of the vintage Naugahyde stock from Jettrim's original creator Gary Hart's private stash. RIP in Gary. They delivered an awesome custom seat and mat kit. Icing on the cake included super trick titanium rainbow head nuts, bolts, and washers from Luke Crane at Powernuts.

Monte put everything together, like a surgeon performing heart surgery, time for her big reveal. Team Goatcher called in the troops! Leading the charge was Greg Cobb — junior racer Jack 'the Ripper' Cobb's dad and my right-hand man — who is breaking into cinematography and we created an 18-minute tell-all video.

We can't thank Mark enough for this once in a lifetime opportunity to recreate history!

God bless jet skiing. Together We Win. **PR**



Together We Win



"After I watched Jet Dreams and read all the jet skiing magazines, my favorite rider and jet ski idol was none other than Harry Goatcher. I got into jet ski racing because of him. I wanted to replicate my ski with the vibrant stripe design reminiscent of the old fruit stripe chewing gum."

Mark Bove President Bove's, Inc.



Mark Bove circa 1995 Kawasaki 440 Superstock

Bomber

SAFETY EYEWEAR

**BOMBER EYEWEAR
PROUDLY SUPPORTS**

**HAULIN'
HARRY GOATCHER**

AND HIS RACING TEAM!

**LET'S GO
TEAM GOATCHER!**



**"TOGETHER
WE WIN"**

PHOTOS - GREGORY COBB

BOMBEREYEWEAR.COM

  @BOMBEREYEWEAR



Exploring Hidden Gems and Majestic Falls:

THE 4TH ANNUAL KENTUCKY PWC RIDERS WATERFALL EXTRAVAGANZA

Story and photos: Cory Eads



Kentucky PWC Riders hosted its 4th

Annual Weekend Waterfall Extravaganza at Dale Hollow and Center Hill Lakes in Tennessee. Joined by the Great Lakes Ski Riders we had a good turnout of 40 skis. The group started off at Sunset Marina to a hiking waterfall gem hidden up a creek deep in the hills. After a brief stop at the waterfall, we headed toward swinging bridge for swimming and pictures.

To celebrate Kentucky PWC Riders' 5th anniversary, I wanted to give back to members and newcomers. Thanks to generous donations from Pro Rider Watercraft Magazine, WavesRX, Rider Coolers, and Great Lakes Ski Riders, we had amazing giveaway items at lunch at Mitchell Creek Marina followed by visits to two more waterfalls on Dale Hollow.

We saved the best for last-Center Hill Lake where I guided the group 57 miles from Edgar Evins boat ramp to Rock Island and Twin falls. What an awe-inspiring sight: a hundred yards of endless waterfalls culminating in the breathtaking Twin Falls. We stopped at 2 new waterfalls I recently discovered showcasing the stunning scenery surrounding this lake.

Afterward, the group enjoyed lunch at Fishlipz Restaurant. Energized, we headed to the 136ft Burgess Falls, capturing photos and climbing around the amazing cascade, concluding our ride at the 80ft Fancher Falls, swimming behind the falls and relaxing.

On behalf of myself and admins we thank our members for helping us grow and the vendors who supported us. There are so many wonderful people in this community and we're happy to be part of it. **PR**





**LOOK FAST
>>> and GO FAST**

**Worldwide
Shipping!**

UNLIMITED

UNLIMITED is a Japanese brand for watercraft parts and apparel that is involved in the design, development, manufacturing and worldwide marketing and sales of apparel, accessories, equipment and services.

What's Included:

- Carbon Fiber Top Coated or Glassfiber Hull
- Waterbox and Silicone Couplers
- Handle Mount
- Rear Sponsons
- Ride Plate
- Splash Guard
- Side Splash Guard
- Pump Shoe, Plate



Introducing

AQUA X

A New lightweight fixed steering hull to push yourself to a whole new world.



UNLIMITED-PWC.COM



@unlimited_pwc



JP RACING INC.

WWW.JPRACINGONLINE.COM



JPRACINGONLINE



JP_RACING_INC

SERVING 2 LOCATIONS

**FT. MYERS
FLORIDA**

**MOORSEVILLE
NORTH CAROLINA**

📞 239.980.0597

📞 704.838.5539

SPECIALIZING IN

SEADOO AND YAMAHA

BOLT ON PERFORMANCE KITS

RE-FLASH

MAINTENANCE

POWDERCOATING

FABRICATION

REPAIRS

OEM PARTS



**BUSINESS HOURS
9AM-4PM MON-FRI**





Event Recap:

2024 SBT GREAT LAKES WATERCROSS TOUR

Rounds 3 and 4



By: Jaymi Bohat, Great Lakes Watercross Promoter
Photos: Troy Fisher



The picturesque beach of St. Feriole Island in Prairie du Chien, Wisconsin came alive during rounds 3 and 4 of the 2024 SBT Great Lakes Watercross Tour. This exciting event, presented by Prairie Motorsports, brought top racers from across the region to compete on the mighty Mississippi River.

EVENT HIGHLIGHTS:

ATV Giveaway: Prairie Motorsports, renowned as one of the top Kawasaki dealerships in the country, hosted an exclusive ATV giveaway for race participants. The lucky winner was Madison Elders.

Push Industries Cash Giveaways: Generous sponsors Push Industries provided cash giveaways to participants in the Ski Lites class:

- Reese Gahagan, Junior Ski Lites winner, took home \$100.
- Brodie Murphy, Junior Ski Lites won \$50 and an aluminum pump shoe.
- Emerson King, Novice Ski Lites winner, received \$100 in raffle prize money.
- Travis Branson, Novice Ski Lites, won \$50.
- Marvin Gahagan, Pro-Am Ski Lites, won a \$100 raffle prize.
- Jeff Hansen, Pro-Am Ski Lites winner, earned a whopping \$400 cash prize.

Weather and Conditions: Despite forecasts predicting thunderstorms and flooding, races proceeded without a hitch. Sunday saw beautiful weather and ideal racing conditions on the river. Special thanks to the dedicated course marshals who ensured the river was clear of debris despite rising water levels.

Attendance and Atmosphere: The event drew a vibrant crowd of spectators and racers. Prairie du Chien, with its stunning scenery and welcoming community, was a favorite among participants, who appreciated the fantastic race site.

Thank you to all racers, sponsors, and spectators who made the 2024 SBT Great Lakes Watercross Tour in Prairie du Chien an unforgettable experience! PR



Troy Fisher PHOTOGRAPHY

 **FREE SHIPPING**
Free shipping on all orders over \$150

 **PERFECT PITCH GUARANTEE**
Love it, or return it for a free repitch to get it right

 **OVER 35 YEARS EXPERIENCE**
We know impellers

 **SAFE & SECURE SHOPPING**



LEADING EDGE IMPELLERS

THE LEADERS
IN HIGH PERFORMANCE IMPELLER TUNING/REPAIR



PROFESSIONAL SERVICE= NO GUESSWORK

- Over 35 years of impeller expertise
- Every impeller we sell is quality checked for correct pitch & balance



- "Factory Refresh" service: includes rebuilding your impellers outside diameter – increasing efficiency, reducing cavitation and maximizing performance
- We provide accurate blade pitch, balance and blueprinting specs on all impeller repairs



- Pro-Tune, impeller repitching service
- Vast knowledge of every PWC & jetboat impeller ever made
- Exclusive "Perfect Pitch" guarantee

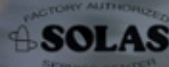

2020 VINTAGE **WYLAND REDEN**
SKI WORLD CHAMPION

www.LeadingEdgeImpellers.com

(949) 229-7339

sales@leadingedgeimpellers.com

  @leadingedgeimpellers



**EXPRESS YOURSELF
THROUGH CUSTOM DESIGN**



AVAILABLE NOW 

REVDUP APPAREL

CUSTOM DESIGN SERVICES

The first step to an awesome, custom-made team jersey is the creation of the design. Select the design option that is best for you and our customization experts will guide you through the rest of the process. Your unique jersey and teamwear design will be ready in no time!

- OUR DESIGNERS WILL CREATE AN EXCLUSIVE DESIGN JUST FOR YOU AND YOUR ORGANIZATION.
- WE OFFER LONG AND SHORT SLEEVE JERSEYS, HOODIES, SWEATSHIRTS, HATS, AND TANK TOPS FOR MEN, WOMEN, YOUTH.
- SHIPPING IS HANDLED BY OUR TEAM SO YOU DON'T HAVE TO WORRY!



INFO@REVDUPAPPAREL.COM

1 904-860-2586

WWW.REVDUPAPPAREL.COM



AVAILABLE NOW 



Photos: Tony Vo

JUNIOR RACER'S JET SKI RACING JOURNEY TO POLAND

The WGP#1 Grand Prix is the pinnacle of jet ski racing, with three rounds: Poland, Lake Havasu City, Arizona, and the finals in Pattaya, Thailand. Andrew Vo, Jettribe's Junior racer, and his family spent two weeks in Poland for the WGP#1 World Grand Prix / Jettribe European Championship Jet Ski Race. Competing against riders from 35 countries, Andrew felt the pressure, especially with sponsors BNJ, Peter De Smet, Kylie Elmers, and Team Flamingo of Thailand watching from the shore. The event was televised to 800 million households, adding to the intensity.

Racing was only part of the Vo family's adventure in Poland. They arrived six days early to explore Warsaw, immersing themselves in local culture and history. The family visited non-tourist spots, interacted with locals, and toured Kozminski International University, which Andrew might attend for a semester.

When race week arrived, the Vo's faced the challenge of competing halfway around the world with minimal gear. However, their international racing "family" was there to support them. Peter DeSmet, close friend and IJSBA Europe race organizer, sponsored Andrew with a Yamaha 4-stroke Superjet, while the BNJ race team handled everything from ECU tuning to pit support. The Flamingo Thai Team provided encouragement and help from the shore.

Andrew's strategy was simple: race his best and avoid finishing last. Competing in the stacked Junior 4-Stroke Lites class, Andrew held his own against strong competitors from Estonia, UAE, and Latvia. Despite his ski being stock, he managed to stay ahead in the races, thanks to determination and skill.

In three motos, Andrew consistently placed third, securing an overall third-place finish on the podium — his most significant achievement yet. One of the highlights was when Andrew and Ali Alalii from the UAE, finished second and third, their proud dads shaking hands on the shore.

The Vo family values the experiences and friendships gained from this journey more than the racing itself. Racing jet skis is a platform for them to explore the world, meet new people, and create lasting memories. The Vos believe while racing titles and trophies fade, the memories and friendships made along the journey last a lifetime. **PR**



TPE

TORRENT PERFORMANCE ENGINES



TORRENT PUMPS
TORRENT PERFORMANCE ENGINES

148MM TORRENT SET-BACK PUMP

\$1295.00 SPECIAL
LIMITED QUANTITIES



TORRENT

TORRENTPUMPS.NET

EMAIL: TORRENTPERFORMANCEENGINES@GMAIL.COM

- * Performance
- * service
- * Fiberglass Repair



LACEY POWERSPORTS

www.laceypowersports.net

609-693-8485



@laceypowersportsinc



@laceypowersports

BEER, BAIT,
BREAKFAST
SANDWICHES,
...B...B...B...



OH YEA,
BOAT PLUG.

I ASKED YOU
TO PUT THE
PLUG IN.

I TOLD YOU
TO GET A
VERSIPLUG!



PH +1(908)256-5541

@THEPWEDOCTOR

PWEDOCTOR.COM



boatplug.com



@VERSIPUG



THEPWEDOCTOR

SPECIALIZING IN HIGH PERFORMANCE



FULL SERVICE MACHINE SHOP 2 AND 4 STROKE ENGINES

- STOCK AND PERFORMANCE ENGINE BUILDING AND REBUILDING
- CYLINDER BORING & HONING
- FULL SERVICE MACHINE SHOP
- FLYWHEEL LIGHTENING
- FROM MILD TO WILD
- CUSTOM DOMES
- HEAD MILLING
- BIG BORE
- PORTING
- DECKING



Erickson Machine & Performance



Erickson's Machine & Performance LLC

ERICKSONMAP@GMAIL.COM

SaintsofSpeed

Got Gloves??



RIDE DIFFERENT ✨

@SAINTS_OF_SPEED

SAINTSOFSPED.COM



HERE TO KEEP YOU
ON THE WATER



**WEAR
RINGS**



**JET PUMP
REPAIR KITS**



**TETHER
CORDS**



**DRIVE
SHAFTS**

DISTRIBUTED BY:

**AUTOMATIC
DISTRIBUTORS**

BCS



GAMMA



BOOK NOW

PHOTO AND MEDIA PACKAGES

COVERING THE BIGGEST INTERNATIONAL RACES

- WORLD FINALS, USA
- GRAND PRIX OF LAKE TOBA, INDONESIA
- WORLD SERIES FINALS, THAILAND

CONTACT ME FOR PRICES AND AVAILABILITY

dieter@braapshots.com

IG: @Braapshots

www.braapshots.com



@Braapshots

Follow me!

Braap
Shots

3RP

NEW! BILLET ENGINE OIL FILLER
CAP AND KNOB SETS



YAMAHA WAVERUNNER FX
REAR COMPARTMENT
BILLET LATCH SET



3RPERFORMANCE.COM P: +1 321.999.9975 @3R_PERFORMANCE



TUNE IN MONDAYS 7PM EASTERN

#CardoneRacecorner #MondayNightRow

#TheBrandTheyLove #SettingTheBarHigh



@239RACEBOAT

SADIE MIR

PROUD JARRITOS MOTOSPORTS RIDER



LSP REVOLVER



READY TO RIDE
\$12,500



FEATURES

- VISUAL CARBON EPOXY-INFUSED HYBRID HULL
- HIGH OUTPUT 760CC
- 155MM 12-VANE THRUST SHREDDER SETBACK PUMP
- BILLET TRIM SYSTEM
- LSP SPEC PERFORMANCE IMPELLER
- HIGH PERFORMANCE LAYDOWN EXHAUST
- LSP LIGHT WEIGHT BILLET FLYWHEEL
- DUAL 46MM MIKUNI CARBS
- THRUST BILLET HIGH COMPRESSION HEAD
- 62-T BASED PERFORMANCE IGNITION
- HYDRO-TURF PRO-SERIES CUSTOM MAT KIT

PREVOLVER S1

POWERED BY 

DEBUTING AT
WORLD FINALS



S1@leestoneproducts.com
LSPREVOLVER.COM

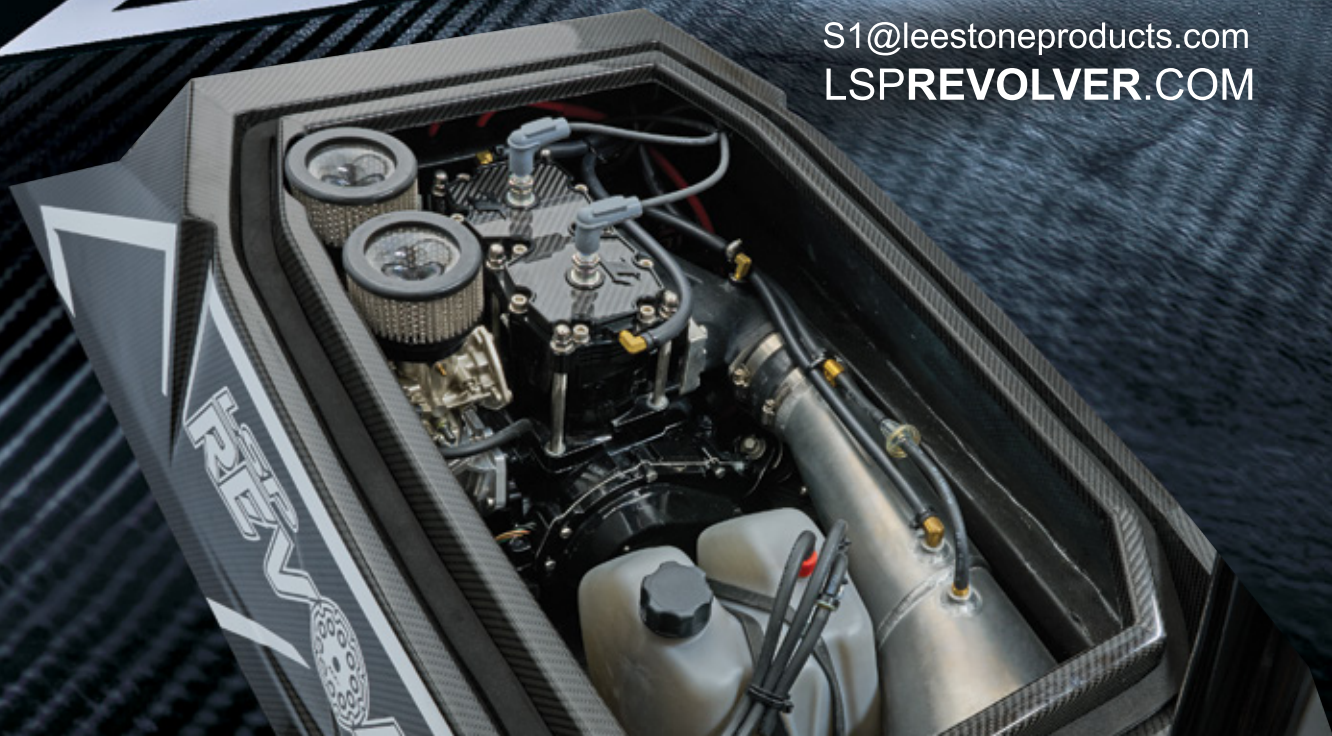

1994 KAWASAKI SC650

WOUNDED WARRIOR PROJECT/ SUPER CHICKEN



Photo: Jessica Waters

David Oski is a proud 5th generation military member, serving as a F-15 Crew Chief in the United States Air Force with the 104th Fighter Wing at Barnes Air National Guard Base in Westfield, Massachusetts. Pro Rider met David several years ago when he first ventured into the world of freestyle and quickly became an adept freestyle competitor and performer.

Shared David, "This ski was built to raise awareness and help support the WWP and all service members that protect our freedom every day! Their bravery, dedication, sacrifices and devotion to this great country are never forgotten."



BUILD SPECIFICATIONS

- ★ Kawasaki 650 with .50 over pistons
- ★ 650 MSD Enhancer
- ★ Jet Dynamics intake grate and custom extended ride plate
- ★ Coffman exhaust system
- ★ Kawasaki 800 SXR cut back prop
- ★ Mikuni 44 SBN carbs

PAINT JOB DONATED BY:

Tony Bordon
BodyWorks Unlimited East
Longmeadow, Massachusetts

SEAT COVER AND PRO SERIES TRACTION MAT KIT SUPPLIED BY:

Hydro-Turf Clearwater, Florida

KEEPING THE WWP-SKI CLEAN:

Nanette Delfaco-Moreno
Jet-Renu/Pet-Renu
Corona, California

BUILD:

Wayne Ordon *WetWerX Water & Snow*
Schenectady, New York

TUNING:

Luke Stocks *Showtime Freestyle*
Plainville, Connecticut

INTAKE GRATE AND CUSTOM EXTENDED RIDE PLATE:

Glen Dilworth *Jet Dynamics* Burley, Idaho

FUTURE BUILD:

We would like to upgrade the motor (750 or larger), electronics, pump, impeller and make a high back seat to add support for riders with disabilities.

Donations are welcome! Please contact David Oski @ Davidoski03@gmail.com if you would like to participate in the 2025 rebuild! **PR**





How are you making the world a better place?
Saving vacations one "thank you" at a time.

"Laughlin NV is a mini Vegas with a river filled with rental jetskis and boats. Most people have no idea what they're doing. I do my very best to help with break downs or flipped over skis or accidents Just a small town hero trying to make the world a better place."

Mike Neuman (Sideburns)

"Real Heroes Ride With JetTribe"

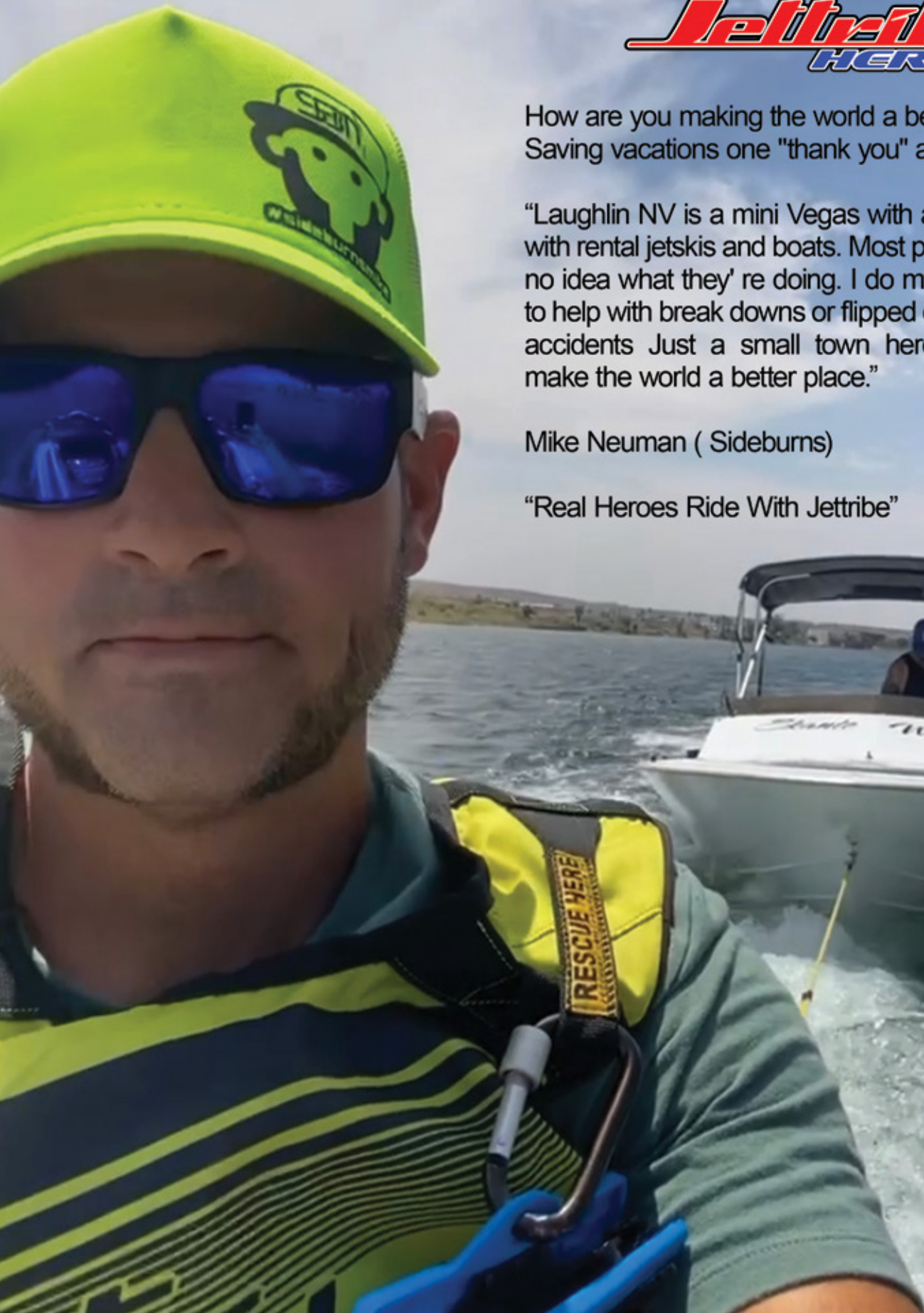

Ph. USA: 951.246.3147 | Web: jettribe.com



@jettribe

**Multiple New Venues Unique Track Designs
and Successful Livestreaming**

2024 JETTRIBE NAUTIWATER SERIES OF CHAMPIONS

By: Justin Smith, Race Director
Photos: Charles Guinchard @CGPhotos,
Ken Gallagher

MID-AMERICA TOUR STOP

The Jettribe Series of Champions hosted an IJSBA World Championship Qualifier in Altus, Oklahoma, merging 321 Kawasaki Mid America Watercross Series with the Ride Now Lonestar Watercross Series. Newly completed, the Altus Reservoir provided a challenging, world championship-style course. Racers from the West Coast, including the Best of the West and Lake Havasu Series, competed for National High Points in an exciting season-long championship chase. Arizona's Team Kommander excelled in the GP classes, while tight points battle in the Amateur and Junior Classes showcased the sport's growth. Excellent livestreaming by Charles Guinchard expanded the event's reach and visibility.



2024 IJSBA JETTRIM JUNIOR NATIONAL CHAMPIONSHIP RECAP

The Jettribe Series of Champions held the exclusive IJSBA Junior Championship in Altus, Oklahoma, the only event of its kind worldwide. For racers aged 8 to 17, this championship has become a crucial platform for emerging talent. The event featured individual slalom and closed course racing, drawing 114 youth entries for a fiercely competitive weekend. Livestreamed commentary by Jason 'Psycho' Ward added to the excitement, with a goal to elevate young racers to national recognition, preparing them for the World Finals. The championship concluded with the crowning of the 2024 Jettrim Junior National Champions, where Jettrim office chairs and custom-made Superbowl-style gold rings were awarded, becoming instant fan favorites.





IJSBA SOUTH CHAMPIONSHIP AND USA CENTRAL CUP RECAP

Jettribe's Series of Champions, covering three regions — Mid America, LoneStar, and Lake Havasu — set a record with 2,200 entries in 2024. The third new venue of the year, Lakee Lavon, Wylie, Texas, hosted the Nauti Water Racing and Jettribe events, home to sponsor Dales Jet Sports. Here, Dale Swanson was honored for his 40 years of contributions to jetski racing. Lake Lavon is rumored to be the home waters of Rob Van Winkle, AKA Vanilla Ice. The Ice Man didn't show but 106 racers with 160 entries did to compete for the IJSBA Central Cup.

The Texas sun bore witness to intense competition, with racers from all series vying for victory on a uniquely designed dual-split track. The track's dual timed starting cadence and ample passing room tested both mental and physical prowess. Livestream coverage by Charles Guinhard drew over 40,000 views, boosting awareness for the series and its sponsors. The double points races fueled the National High Points Chase, culminating in a fiercely contested USA Central Cup. Racers battled in a 3-moto format, striving for geographic bragging rights.

The series is grateful for the support of sponsors and the safe, successful execution of each event, celebrating both victories and the sport's continued growth! PR

FULL RESULTS AND INFORMATION:
[HTTPS://NAUTIWATERRACING.COM/](https://nautiwaterracing.com/)



Did you miss the action?

Scan and watch videos by Charles Guinhard Photography to keep you occupied until next season starts!





PIER 13

1301 Sinatra Drive North Hoboken, NJ 07030

www.NewYorkCityJetski.com

1-646-589-5953

nycjetski@gmail.com



Hudson River Yacht Club

1375 River Road Edgewater, NJ 07020

www.HudsonRiverJetski.com

1-201-220-8181



eyecandyproducts.net



RIDER: SETH FUHMAN





#GetEquipped

#GetEquipped

#GetEquipped

#GetEquipped

#GetEquipped

#GetEquipped

#GetEquipped

AOMC

AOMC

AOMC

Millions of parts and accessories, no matter the sport!

visit: www.aomc.mx



THE GREAT BAHAMAS CHALLENGE

Story and photos: Danni Mitti, Bahamas Challenge Administrator

Ride of a Lifetime

Bahamas Challenge is a group of daring, like minded individuals coming together for the ride of a lifetime. This is a bucket list trip for many riders, with participants joining from all over the United States including Maryland, Pennsylvania, Texas, and an adventurous rider who drove 41 hours from California to join us on our journey. Over 100 riders participated this year, to our knowledge, the biggest group of jet skis/boats to ever cross!

The excursion takes place over 4 days out of Crandon Park Marina in Key Biscayne, Florida where we head out to Bimini, Bahamas for several days. Each day was jam packed with fun filled adventures such as snorkeling

inside shipwrecks, visiting plane wrecks and jumping from island to island, soaking in all the beautiful wonders the Bahamas offer.

At all times, we are laser focused on safety and have several lead boats as well as 2 dedicated watercraft in the rear of the group, Co- organizers Shaun Prabhudial and me, the very last 2 people in the back of the pack to ensure everyone is okay. Shaun and I devote many hours organizing this major trip. None of this would be possible without Shaun's hard work and dedication.

Our name, Bahamas Challenge, says it all — this is no small feat. It demands extensive planning and constant monitoring of weather conditions to ensure everyone's safety. This isn't something you can just decide to do one morning. While it's truly an incredible ride, we want to make sure everyone understands the importance of careful planning and respect for the elements. **PR**

Noteworthy Insights:

- ❑ Approximately 60 miles of open water ocean riding
- ❑ Under favorable weather conditions, the trip from Miami to Bimini takes two hours at a speed of 25 knots
- ❑ Recommend no less than 5 extra gallons of fuel
- ❑ Previous riders do not recommend riding two people on a PWC during the crossing
- ❑ A VHF radio is crucial for during any jetski crossing or boating adventure.
- ❑ Traveling to the Bahamas from the United States a passport is required



**FOR MORE INFORMATION VISIT
[HTTPS://BAHAMAS-CHALLENGE.COM/](https://bahamas-challenge.com/)**



SCAN FOR



INSTAGRAM!



SCAN FOR



YOUTUBE!

**CALL OR TEXT (347)225-5113
LOCATED IN HOWARD BEACH, NEW YORK**



ALL YOUR DESIRED JETSKI REPAIRS & TUNING

**SEADOO | YAMAHA | KAWASAKI
MAINTENANCE**

CUSTOM TUNING VIA HPTUNERS

MOTOR BUILDS

PERFORMANCE KITS

WINTERIZING

SCAN FOR



TIKTOK!



**MEDIA
MAGNET**
BY PAPERKIT.COM

HAULING THIS HAS NEVER BEEN EASY

WITH STRAPINNO RETRACTABLE RATCHET STRAPS,
TIE DOWN ANYTHING IN MINUTES!

- » SAFE & SECURE RATCHET STRAPS FOR ALL YOUR HAULING NEEDS
- » EFFORTLESS STRAPPING AND RELEASE
- » UNIQUELY VERSATILE
- » READY TO USE
- » AFFORDABLE
- » STURDY HARDWARE
- » ALL RATCHET STRAPS MADE OF HIGH QUALITY, INDUSTRIAL GRADE WEBBING
- » NO MORE TYING NO MORE KNOTS
- » AUTO RETRACT WITHOUT TANGLING
- » OPTIONS DESIGNED ESPECIALLY FOR WATER ACTIVITY ENTHUSIASTS



 **strapinno**
RETRACTABLE RATCHET STRAP



STRAPINNO

WWW.STRAPINNO.COM

@STRAPINNO

**HUGE
TIME SAVER**

Strapping & unloading
DONE IN A SNAP!



RIDING THE SPRINT BOAT TRACK:

Westcoast Surf Riders Dazzle at Extreme Sports Park 2024 American Sprint Boat Race Half time show

By: Dan Lindgren, President Westcoast Surf Riders | Photos: Jim Flynn, J James Photography

The Westcoast Surf Riders were invited back to entertain the crowds at the American Spring Boat Racing Championships half time show. As the jet sprint sport grows and we continue to provide the half time show, it's great exposure for the jet ski industry. Spectators love watching the skis as they can envision themselves riding a jet ski on the track.

Building and racing a sprint boat is a much taller order due to their higher cost, limited availability, the need for a full pit crew and all that goes with having a sprint boat racing team.

What's it like to ride a sprint boat track on a jet ski? It is a lot different than riding on a lake! The track is 12-14 ft wide and 2-3 ft deep. This creates a push back effect when the water is compressed against the mud surfaces below and on the sides of the slough. The shallow water push back helps in the corners. Precision driving is crucial to staying on the track. A slight bump can easily send a rider sliding onto land, a common occurrence for both jet skis and sprint boats.

We had an amazing weekend at Extreme Sports Park in Port Angeles, Washington! Big thanks to Jim Flynn for capturing the action, HenRy Li for backflip entertainment, all the riders, and ASBR for including us in their incredible event. Don't miss the next race after Labor Day — it's a must-see for jet boat and jet ski enthusiasts! **PR**



JETXCO

Introducing Jetxco Essentials — the ultimate tools for Jet Ski owners. Our impeller jam removal tool and rope-cutting tool are the must-have companions for every adventure on the water.

THE IMPELLER JAM REMOVAL TOOL features a 360° access pick, allowing you to remove debris and obstructions with ease while maintaining strength and torque.

OUR ROPE-CUTTING TOOL is designed specifically to cut ropes, nets, leashes, and other objects wrapped around the drive shaft of your jet ski. Equipped with a stainless-steel serrated blade and a protective rubber cover, it ensures efficient and safe removal.

With these tools in your arsenal, you'll be prepared to handle unexpected challenges and protect valuable water time.



WWW.JETXCO.COM



POWER IN NUMBERS

RAISE YOUR BOATS STYLE; LOWER THE IMPACT ON YOUR WALLET



STIFFIE.COM

ABCDEFGHIJKLMNOPQRSTUVWXYZ-0123456789



RACING RETURNS TO THE GOLD COAST!

2024 AUSWCR National Watercross Championships

Story and photos: Craig Milne, Zoomed Images



Sixty-six competitors from Australia and around the world landed on the beautiful Gold Coast for the 2024 Australian Watercross Championships. Riders from Sweden, the USA and NZ added a welcome mix of competition.

Whilst run to the IJSBA rulebook, the event ran an exciting somewhat new "Triple Crown" style points system with three, six and eight lap sprint motos making up the first day. Combined points for each day of racing were converted to a simple 1, 2 & 3 for overall placings for the day with the highest points scorer for the day attracting a score of 1.

Day two all classes completed a single longer moto as their final, apart from GP Ski that had two motos. With the points system run the same as the first day it was important to race hard both days.

The scoring platform created close results with tied points in many classes, none as close as GP Ski with a 3-way tie for 1st. Day 2 score determined the winner as the "tie breaker". The scoring system provided excitement often missing in PWC racing.

Fantastic weather and the track in the heart of the Gold Coast, attracted numerous spectators on land and water, excited to see PWC racing return here.

Post event, everybody convened at Café Catalina for prize giving and well-earned refreshments. Trophies for 1st place were something not seen since the halcyon days of racing in Australia with the 1st to 3rd Australian residents taking home a number plate with an "A" designation as recognized by IJSBA.

At the end everyone had a smile on their face. The club committee and volunteers deserve high praise for organizing such an ambitious event, especially considering their first event was only 14 months ago. In that short time, they've managed to host a flagship event at a world-class location. **PR**





OVERALL PLACINGS

MASTERS SKI 1500 STOCK

- 1ST Doug Porter
- 2ND Tony Blair
- 3RD Shane King

AMATEUR SKI 1500 STOCK

- 1ST Todd Christie
- 2ND Jack Voskuilen
- 3RD Max Moran

PRO-AM REC LITES

- 1ST Christian Cagnard
- 2ND Troy Tsakissiris
- 3RD Greg Hack

SKI LITES

- 1ST Tom Aiken
- 2ND Ollie Morris
- 3RD Lauchlan Gibbens

800 2-STROKE

- 1ST Brian Colreavy
- 2ND Taylor Porter
- 3RD John Sloan

STOCK RUNABOUT

- 1ST Mitch Wayt
- 2ND Noah Skippis
- 3RD Matthew Atallah

BLASTER GP

- 1ST Rhett Terranova
- 2ND Cameron Rylance
- 3RD Tim O'Neill

EXPERT SKI STOCK

- 1ST Harley Ritchie
- 2ND Tom Aiken
- 3RD Tony Grey

NATURALLY ASPIRATED OPEN

- 1ST Troy Tsakissiris
- 2ND Greg Hack
- 3RD Dan Colburt

SKI GP

- 1ST Jake Beekman
- 2ND Jayden Richardson
- 3RD Jet Cavanagh



AUSTRALIAN WATERCROSS DESCRIPTION OF COURSE

Blue and green split used to limit the numbers starting off the line, the 2 tracks give space for riders starting from the beach.

2 tracks give space for riders starting from the beach.

Yellow buoys right turn

Red buoys left turn

Different track sections for standup skis and runabouts

Decision buoy to choose the green or blue split during racing laps.

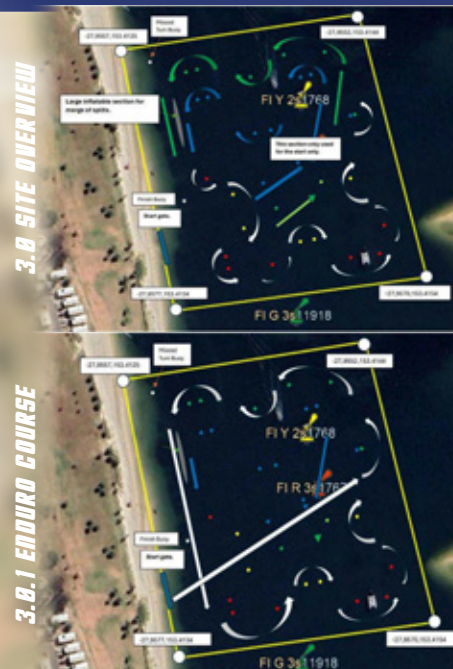



LIQUI-MOLY PRO WATERCROSS TRIPLE CROWN FINALE



Photos: Skylar Mack Ramgeet



The 2024 Pro Watercross Series made an exhilarating stop at Tugaloo State Park in Lavonia, Georgia, as part of their LiquiMoly Triple Crown Finale drawing top athletes and enthusiastic crowds to the picturesque venue. The event showcased thrilling high-speed races on the familiar waters of Lake Hartwell. Tugaloo State Park's six-lane mega ramp makes the park a popular site for large fishing tournaments, as well as recreational boating, and the ample parking and easy launch access make it a perfect site for watercross racing.

This tour stop highlighted the skill and determination of the riders and underscored the continued growth of watercross racing in the region! **PR**



FULL DETAILS AND SCHEDULE: WWW.PROWATERCROSS.ORG





ANDERSON
POWERSPORTS
AndersonPowersportsAZ.com



POKER, PRIZES, AND COMMUNITY SPIRIT:

2ND ANNUAL NAUTI GIRL CREW POKER RUN

By: Renee Hill,
Leader, Nauti Girl Crew

Photos: Zee Khan
Zee Picture Perfect

The sun rose over Astor, Florida, casting a golden glow on the St. John's River. The air was filled with excitement as the Nauti Girl Crew prepared for their 2nd Annual Poker Run which promised to be bigger and better, with riders from all over gathering to participate in the fun-filled day.

A lively group of jet skiers known for their adventurous spirit and camaraderie, the Nauti Girl Crew meticulously planned the event using the KnowWake mapping app to chart a course along the river with five stops where participants collect poker cards, each stop hosted by a different group or sponsor, ensuring a variety of activities, games, and treats.

Thank you to our poker stops provided by Pro Rider Watercraft Magazine, offering a free magazine for every rider! The Agitando Jet Ski Group hosted a fun game of cornhole and giveaways. Florida Ski Riders contributed giveaways and raffle prizes, while SandShark provided anchor giveaways. A special, heartfelt thank you to our own NGC member, Nancy Lucas for her fundraising efforts to support a rider battling cancer. Her stop truly showcased the jet ski community as a family.

As the day progressed, riders chilled in the cool river waters, listened to music, and ate delicious BBQ provided by the West Coast Watercraft Club. The aroma of grilled food filled the air as everyone gathered to enjoy the meal and share their experiences of the day.

Finally, it was time to announce the winner of the best poker hand. The anticipation was palpable as the cards were revealed. Cheers erupted as the winner, Sabrina Sanchez, was announced, taking home a huge trophy and bragging rights.

As the sun began to set, the Nauti Girl Crew thanked everyone who made the event possible. Special thanks to additional giveaway sponsors Banshee Power Sports, Shan Sharp, Devil Dog Ski Repair, and Sanchez Interpreters. Their support and enthusiasm made the day unforgettable.

The 2nd Annual Nauti Girl Crew Poker Run was a resounding success, filled with laughter, adventure, and community spirit! As riders packed their gear and headed home, they were already looking forward to next year's event. The Nauti Girl Crew again proved that with teamwork and a sense of fun, anything is possible. Join us next year and try your luck for a winning poker hand! **PR**





BOOK YOUR PHOTOSHOOT TODAY!!!!

MIAMI #1 JETSKI PHOTOGRAPHER

305.300.8279

WWW.MVP-PRODUCTION.NET

MVP_PRODUCTION



CAPTURING THE ACTION ONE CLICK AT A TIME

FOLLOW US HERE >>>



FULL THROTTLE WATER X

ACT FAST BOOK NOW!!

KDW PHOTOS
121 PHOTO

\$75 PHOTO PACKAGE

Racer's Photo Package All Day Race Coverage
14 Final Edited Images Online Viewing and Downloading

HAVASU LANDING RESORT & CASINO

CONTACT US FOR MORE INFORMATION & BOOKING
KENNY WONG (408) 607-0369
WWW.KDWPHOTOS.COM IG: @KDWPHOTOS

Follow us on Instagram

WWW.KDWPHOTOS.COM IG: @KDWPHOTOS (408) 607-0369

"THE GAME CHANGER"

RUTHLESS_RXPX



RUTHLESS

BUILT & TUNED *RACING*

BRP-PWC PERFORMANCE SPECIALISTS

PERFORMANCE PARTS

REMOTE TUNING-ECU FLASH-DATA LOG

DEALER PRICE GUARANTEED

239-887-6848

WWW.RUTHLESSRACINGSTORE.COM



**← SCAN
TO GO
FAST**



RUTHLESS SEA-DOO
CARBON FIBER
COLD AIR INTAKE &
K&N FILTER

RUTHLESS SEA-DOO
230/300
INTERCOOLERTUBING
UPGRADEKIT

RUTHLESS SEA-DOO
230/260/300
OPEN LOOP
COOLING KIT

RUTHLESS
SEA-DOO REMOTE
TUNING DEVICE
STAGE 1-2-3-4

RUTHLESS SEA-DOO
BILLET RACING
CAMSHAFT (DLC
DIAMOND COATED

RUTHLESS SEA-DOO
72/142MM 26PSI
SUPERCHARGER
IMPELLER

RUTHLESS SEA-DOO
CARBON SEAL
REINFORCEMENT
CLAMP

SOLAS CUSTOM SEA-DOO
CONCORD SX-CO-13/17.5
(REBALANCED)
LAUNCH READY

WE SHIP WORLDWIDE SHOP ONLINE

WILD WEST WATERCROSS BRINGS THE HEAT

TO INAUGURAL SEASON WITH EPIC RACES,
INNOVATION, AND CELEBRATIONS



Round two of the Wild West Watercross took place in Bakersfield, California at beautiful Lake Buena Vista Aquatic Recreation Area. Racers from all over California, Nevada, Arizona braved the heatwave and showed up ready for battle. From the new and improved registration trailer to the innovative light system and leader lights, Wild West Watercross is continually striving to bring change and innovation to the race scene.

A total of 89 racers, including 18 newcomers, hit the exciting track. With 15 races, the beach was packed with all kinds of skis. The Blaster gang had one of the largest lineups, alongside vintage skis reminiscent of the '90s racing scene. Jivin' Ivans served delicious smash burgers, tacos, aquas fresca drinks, and snow cones.

Full Throttle Watercross hosted their 2023 awards ceremony, celebrating the season with good times and memories. Special kudos to Deegan Newton, a key figure in the jet ski community, who brought his passion and dedication to racing. Thanks to Colin Richards of PWC Engineering and Precision Watercraft Cleaners, one of Full Throttle's biggest supporters and co-owner.

Round three took place in Sparks, Nevada, set against the stunning Sierra Nevada mountains and Reno nightlife. The last race at Sparks Marina was in 2017, but Wild West is dedicated to making this ideal spot for closed-course jet ski racing an annual event.



By: Annie Cassel / IG: @Braaaapgirl26
Photos: Cliff Cassel / IG: @Casselcreation; Kenny Wong KDW Sports Photos

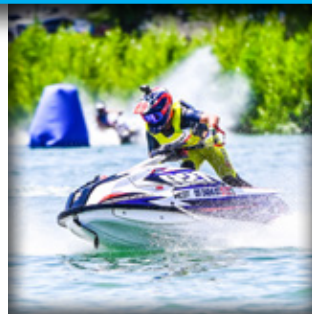



SPECIAL GUEST ANNOUNCER
BOBBY CARDONE
239 RACEBOAT CARDONE CORNER



Riders traveled from southern California, Lake Havasu, northern California, and New Zealand. Twenty-four new riders attended the beginner rider's clinic. With 118 entries two new classes were added, Women's Blaster Stock sponsored by local racer Duv Cardenas, and Junior Vintage Mod.

Sport and vintage had large lineups this season with the popular 'Run Whatcha Brung' class growing. From junior, to freestyle, to fast ski open classes, there is something for everyone!

Thank you to all sponsors — none of this would be possible without your support: Dirty Delta Performance, Sidewaze Design, Reno Hair Extensions, Michael's Reno Powersports, Cassel Creation, Drainspecialist.com, City of Sparks, and Pro Rider Watercraft Magazine for sharing our journey in print.

Thanks to the course marshals for ensuring our safety, and to staff, volunteers, and pioneers Chris Ennis, Nolan and Stephanie Glock, JR Deman, Kevin Chen, and Matt Wright for making it all possible!

For full results and more information visit www.wildwestwatercross.com Stay tuned for 2025 and stay wild y'all! PR

CHECK OUT "ADVENTURES WITH JEFF MARTINEZ" ON FACEBOOK



SCAN TO EXPERIENCE WILD WEST THRILLS AT SPARKS MARINA BY ADVENTURES WITH JEFF MARTINEZ

SHOWTIME FREESTYLE

1000S OF PARTS IN STOCK -
WORLDWIDE SHIPPING

- FREESTYLE JET SKI PARTS
- VINTAGE JET SKI PARTS
- CUSTOM BUILT FREESTYLE JETSKIS

WAX racing HYDRO-TURF GP JET SKI Revolver

WWW.SHOWTIMEFREESTYLE.COM PH: 8608667002 EMAIL: SHOWTIMEFREESTYLE@GMAIL.COM

bpconcepts Visual Performance

Race Imagined...

Race Inspired

www.bpconcepts.com

Angelica Racing & Repair

CALL OR TEXT US TODAY (813) 728-7774
FOR YOUR FREE ESTIMATE

NOW ACCEPTING ALL MAJOR INSURANCES

- CUSTOM FIBERGLASS REPAIR AND PAINT WORK
- HULL MODS & TUNNEL REINFORCEMENTS
- 26+ YEARS EXPERIENCE

BEFORE **AFTER**

FL 3507 PC

@ANGELICARACING @ANGELICARACINGLLC

**ORDER YOUR
STORM NOW!**

**STARTING AT
\$22,990**

EVOJET

EVOJET

STORM

INTRODUCING THE NEW EVOJET **STORM**



WWW.EVOJET-FACTORY.COM

INFO@EVOJET-FACTORY.COM



CHAMBRELLO
ENTERPRISE
Watercraft Performance Specialist

860 Watercraft

- Maintenance
- Repair
- & Performance

#CHAMBRELLOENTERPRISE

PHONE: 860-384-1045 @CHAMBRELLOENTERPRISE



**AZ
FREERIDE
KUSTOMZ**

- CUSTOM JETSKI BUILDS,
PARTS AND ACCESSORIES
- CUSTOM MARINE BUILDS,
PARTS AND ACCESSORIES
- CUSTOM OFFROAD BUILDS,
PARTS AND ACCESSORIES

FOLLOW US ON INSTAGRAM TO
SEE ALL OUR CURRENT BUILDS
IN THE BRAAP CAVE!

WWW.AZFREERIDERZ.COM 760-484-7090 @AZFREERIDE



PHOTOS: Mark Povey



ANTHONY BAKEWELL and **MAISEY** the Cockerpoo of Coventry, United Kingdom. Shared Anthony, "Maisey loves the lake at Kingsbury Jet Bike Centre."



DO YOU HAVE A PICTURE WITH YOUR PET AND PWC?

To be featured, submit photos to cathy@proridermag.com

Catching up with Pro Race and Freestyle Champion **Tony Blair** with his **Groodle - Golden Retriever Poodle, Winston** and several resident "chooks" at his farm on the Gold Coast, Australia. Pro Rider Publisher **Michael Ratti** and mom recently enjoyed a visit with Blair, who, besides excelling in racing and freestyle, is also a top-notch mechanic, proving his skills on and off the water.



Boxers **HANK** and **PENNY** cruising on Lake Sinclair living the good life in Eatonton, Georgia with **LUKE WILSTERMAN**.

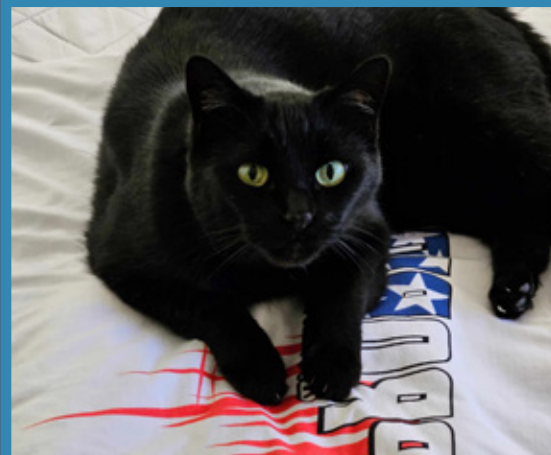

DD Pro Rider T-Shirt Quality Control Inspector and mischief maker at home with Pro Photographers **KEN** and **GENEVA GALLAGHER**, Lake Havasu, Arizona.

DOGGY Splash!

Pet Renu
Quality Pet Care Products

It's important to wash your dog after water activities.

Includes Lakes, Ocean and Bay Water



Unknown high bacterial amounts or other potential forms of contaminants, even dried salt can irritate your dogs skin. Washing off pathogens from local waters is recommended. Clean them with fresh water from the tap and suds them up with Pet Renu shampoo when they are done.

www.petrenu.com



Thrustone



THRUSTINNOVATIONS.COM 561-371-3398  



MOTOOPTION

15% OFF
ENTIRE ORDER
USE CODE - PRORIDER

WWW.MOTOOPTION.COM

YAMAHA LAUNCHES PLAYFUL, BUDGET-FRIENDLY WAVERUNNERS® WITH REVOLUTIONARY DECK DESIGN



Compact, Lightweight 2025 JetBlaster® Series First to Integrate Polypropylene Composite Materials

Yamaha WaterCraft Group recently unveiled the all-new JetBlaster WaveRunner Series, an exhilarating addition designed for riders seeking a lightweight, agile, and compact watercraft.

The JetBlaster Series offers an exciting ride at an affordable price. Measuring 116 inches in length, 44.5 inches in width, and weighing as light as 529 lbs., the JetBlaster Series is the most compact-sized sit-down WaveRunners available.

The series includes four models, each designed to provide a playful and enjoyable riding experience. A standout feature is the reinforced polypropylene deck, a first for WaveRunners. This innovative material enables visually dynamic styling and ergonomic design that fiberglass cannot achieve in a compact watercraft.

The JetBlaster features a painted SMC hull, which provides a glossy, showroom quality appearance with exceptional durability. This hull can be repaired if damaged, ensuring long-lasting performance and aesthetics. This repairability offers significant cost savings compared to other brands' Rec Lite models, which can require a costly hull replacement when damaged.

These new models are powered by the 100-horsepower Yamaha TR-1® marine engine in the JetBlaster and JetBlaster DLX™, and the 110-horsepower TR-1 HO motor in the JetBlaster PRO™ and JetBlaster LTD™. These lightweight, compact, three-cylinder, four-stroke motors deliver class-leading engine performance and fuel efficiency.

KEY FEATURES OF THE JETBLASTER SERIES:

- **Sleek and Sporty Design:** The JetBlaster boasts a sleek, sporty design that complements its high-energy performance, enhancing the rider's experience.
- **Tall, Wide Handlebars:** Provides riders with leverage and control, while new performance grips reduce hand slippage and fatigue when riding all out (exclusive to the JetBlaster PRO).



YAMAHA

Revs Your Heart





- **Foot Chocks:** Strategically placed where the footwells meet the stern, these chocks provide a secure stance for standing up and effectively transfer body weight input to the hull during freestyle maneuvers (exclusive to the JetBlaster PRO).

- **Custom-Tuned Electric Trim:**

This exclusive feature allows riders to adjust the watercraft's riding characteristics from serious to playful.

It enables popping out of the water, performing spins, and other athletic maneuvers (exclusive to the JetBlaster PRO).

- **SMC Hull and 3-Part Polypropylene Composite Deck:** A first for Yamaha WaveRunners, this combination allows for a visually appealing design, comfortable rider ergonomics, nimble handling, and renowned Yamaha durability.

2025 JETBLASTER SERIES MODELS:

The JetBlaster Series features four distinct models to suit various rider preferences:

- **JetBlaster:** The entry-level model with a TR-1 engine, available only in a 2-up option. This model is perfect for those focused more on fun and less on features.
- **JetBlaster DLX:** Equipped with Yamaha's RiDE® system, mirrors, more storage, and a reboarding step, the DLX offers additional convenience and comfort. It features the TR-1 engine and is available in 2-up or 3-up options.
- **JetBlaster PRO:** This freestyle-focused model includes the RiDE system, a 4.3" Connex® screen, custom-tuned trim with an auto trim feature, wider handlebars, and foot chocks for a sportier ride. Powered by the TR-1 HO engine, it is available in 2-up or 3-up options, catering to those who seek enhanced performance and technology.
- **JetBlaster LTD:** The all-inclusive LTD comes with the RiDE system, a 4.3" Connex screen, Auto Trim, the TR-1 HO engine, and an accessory package. It is available only in a 3-up option. The limited accessory package includes a Footwell Audio Kit, a Side Storage Bag, Stern Mounted Storage, and a Mooring Cover. **PR**



Learn more about the exciting Yamaha JetBlaster WaveRunner Series at

RIDEFULLBLAST.COM

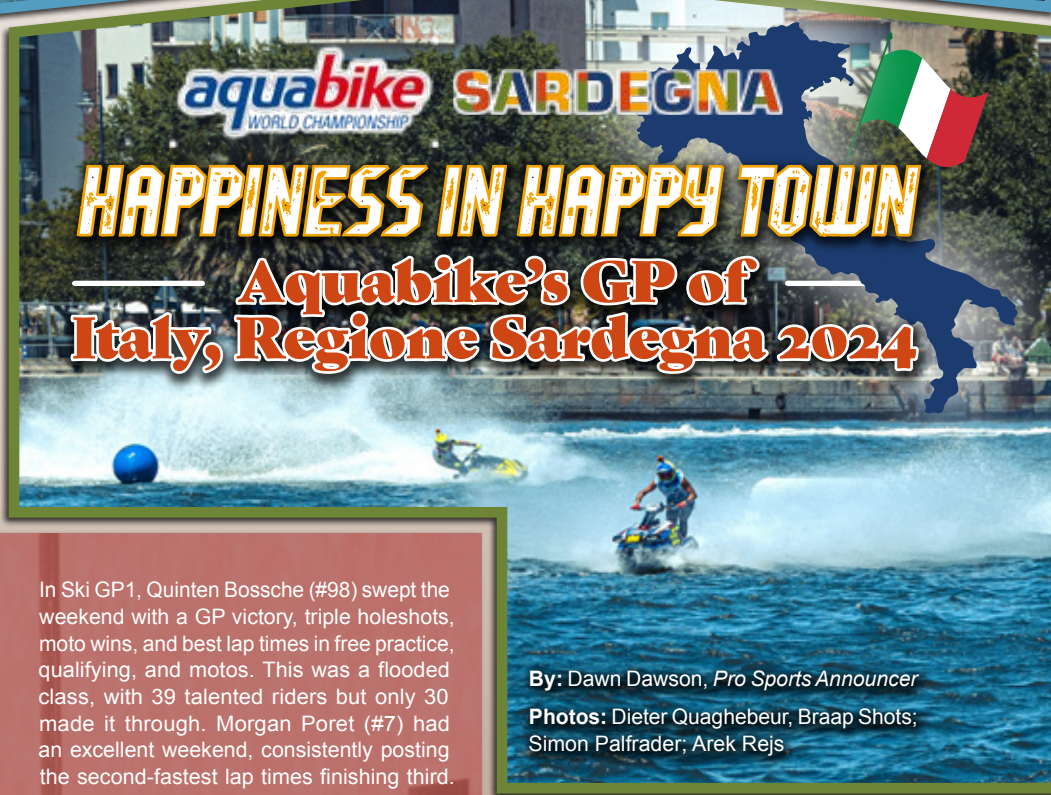

O lbia, known as the 'city of happiness' is a challenging yet welcoming venue for riders and, in the spirit of competition, a stage to be conquered. This year saw one of the best turnouts for Aquabike, with 167 riders from 30 countries across 9 categories. Riders competed not only for precious Grand Prix points and victories but in GP2, GP3, and GP4 they were fighting for World Championship titles.

Belgian Yoni Hamelin (#99) won the Ski GP3 title after three moto wins, while Estonian Mattias Reinaas (#32) clinched both Ski GP2 and GP4 titles. Karl Keskula (#7) of Estonia won the Runabout GP4 title, with Alejandro Prats-Palau (#1) taking the final moto win. French racer Cyrielle Bramm (#43) claimed the Runabout GP4 Ladies title, and Hungarian Csongor Jászai (#60) won the final moto in Ski GP2 but lost the overall to Reinaas. Estonian Mattias Siimann (#71) secured the Runabout GP2 title with a commanding final moto victory.

Siimann continued his streak by taking the coveted Runabout GP1 title, an honor earned in a difficult stacked class. Defending GP winner Samuel Johansson (#4) took the win in moto 2, with Siimann in second, playing a smart game preserving his resources while holding off serial passer Francois Medori (#41). Medori rounded out the podium in third, behind Johansson. Early favorite and multiple world champion Jeremy Perez (#86) was unfortunately plagued by boat difficulties in both motos. Gyorgy Kasza (#5) broke down but led a respectable redemption charge in moto 2, finishing 4th.

In Ski GP1, Quinten Bossche (#98) swept the weekend with a GP victory, triple holeshots, moto wins, and best lap times in free practice, qualifying, and motos. This was a flooded class, with 39 talented riders but only 30 made it through. Morgan Poret (#7) had an excellent weekend, consistently posting the second-fastest lap times finishing third. Morgan and brother Jeremy were thwarted in most motos by Kevin Reiterer (#90), who took any opportunity to pass the Poret brothers. Kevin finished in second.

Other notable performances came from Toshi Ohara (#37), who came in third in Moto 2, and Jeremy Poret (#96) who made a strong comeback after recovering from serious shoulder trouble.

Jessica Chavanne (#99) achieved hard-earned victory in Ski Ladies GP1 despite sickness and a new boat setup. Estelle Poret (#96), after a brief hiatus for injury rehab, made a strong comeback finishing second just two points behind Chavanne. Emma-Nellie Ortendahl (#98) proved her point by taking third place finishes in motos 1 and 2, securing third on the podium. Jasmiin Ypraus

By: Dawn Dawson, Pro Sports Announcer

Photos: Dieter Quaghebeur, Braap Shots; Simon Palfrader; Arek Rejs

(#64), eager to maintain her red bib from the GP of Vietnam, battled technical difficulties in the first two motos but redeemed herself in moto 3 with the win. Another commendable performance came from Benedicte Drange (#10), who finished second in moto 3, her best finish in GP1 to date.

Five competitors participated in freestyle, with Rashid Al Mulla (#3) winning the title thanks to his Bun setup and a variety of tricks, including a double backflip. Italian favorite Roberto Mariani (#1) took second followed by fellow countryman Massimo Accumulo (#5).

Racers are looking forward to another world championship stop in Indonesia in November. **PR**

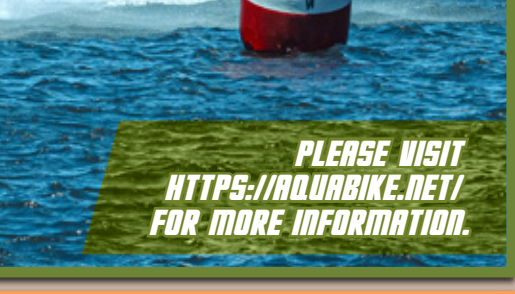

PLEASE VISIT
[HTTPS://AQUABIKE.NET/](https://aquabike.net/)
FOR MORE INFORMATION.



ARIZONA PWC ENTHUSIASTS Scenic Colorado River Ride: Cottonwood Cove to Hoover Dam

Story and photos: Randy Lovato,
Founder Arizona PWC Enthusiasts



Arizona PWC Enthusiasts held its Second Annual Hoover Dam ride from Cottonwood Cove up the beautiful Colorado River to Hoover Dam on the border between Nevada and Arizona. With glass water and beautiful scenery, it was breathtaking as we stopped along the way to take it all in, arriving at Hoover Dam an hour after launching. We explored Emerald Cove and Hot Springs, then visited Willow Beach for gas, lunch, and ice cream! As the day progressed, rising winds added an exciting challenge to the ride, making it even more enjoyable!

A total of 25 skis made this year's ride to Hoover Dam and back safely. This is a must do ride for anyone who loves adventure and the beauty of the Colorado River! **PR**



MISSION

AriZona PWC Enthusiasts, a vibrant community of over 1,100 personal watercraft riders, is dedicated to promoting recreational jet skiing, water safety, and community engagement across Arizona. Our mission is to create an inclusive environment where every member feels valued and supported.

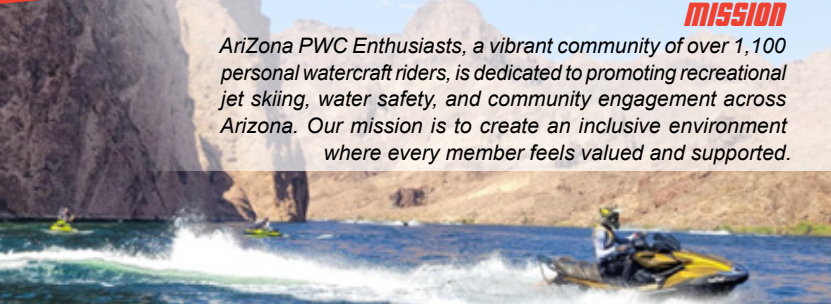

CHAMPIONSHIPS TELL THE STORY

*Broward
Motorsports
Racing*

"BROWARD MOTORSPORTS DOMINATES P1 RACING AS THE MOST WINNING TEAM," "NUFF SAID!"

2016 & 2017
CHRIS MACCLUGAGE



2018 & 2019
ERIC "THE EAGLE" FRANCIS



2022
JIMMY WILSON



2022
SAMMY NEHME



2023
DUSTIN FARTHING



**NO MATTER WHO RIDES OUR SKIS, BROWARD MOTORSPORTS RACING
FINISHES FIRST! DROP THE MIC**

P1 AQUAX RACING TEAM - BROWARD MOTORSPORTS 2024



DUSTIN FARTHING #79



DEVEN FARTHING #6



TALAN FARTHING #521

IF YOU'RE READY TO BE FAST, SHOP WITH BMS-RACING.COM

ORDERS OVER \$100 GET A FREE BMS TEAM HAT

**SHOP & ORDER ONLINE
WWW.BMS-RACING.COM**

*Broward
Motorsports
Racing*

PH: 800-940-3000

USE CODE

BMS10

AT CHECKOUT FOR
10% OFF

FLEXIBILITY AND MOBILITY FOR JET SKIERS

NO EQUIPMENT NEEDED!

By: Kyla Desrosiers, Pro Racer/Fitness Trainer Jet Pump Fit | Photos: Rain Porter, 121 Photo

Jet ski riders know the importance of full-body strength to stay on board and avoid an unexpected swim! Legs, hips, arms, shoulders, core, and spine endure constant strain while riding, but proper stretching can prevent injuries, strains, and sprains.

Daily flexibility exercises are essential. With a background in gymnastics, soccer, competitive cheer, and motocross, I've learned many techniques and developed a stretching routine tailored specifically for jet ski riding.

Stretching and strength training are key for control and stability on a jet ski. The impact of waves can quickly exhaust unprepared muscles, risking fatigue and accidents. A consistent training regimen boosts endurance, improves balance, ensuring a safe, enjoyable ride.

FIVE-MINUTE, NO-EQUIPMENT, PRE-RIDE WARM-UP ROUTINE:

- 1.** Sky reach toe touches: Stand tall, arms up, bend forward to touch your toes. This stretches your back and hamstrings, elongating the spine.
- 2.** Torso twists: Feet shoulder-width apart, hands on hips, twist torso gently side to side to warm up your core and enhance spinal flexibility.
- 3.** Leg swings: Hold onto a stable surface, swing one leg forward and backward, then switch legs. This stretch targets hip flexors and hamstrings.
- 4.** Hip openers/closers: Stand tall lift one knee to hip height, open out to the side and bring back in. Repeat other side. This loosens hip joints and improves mobility.
- 5.** Quadriceps stretch: Stand on one leg, pull the other foot towards your buttock with your hand, keeping knees close together. This stretches the front thigh and improves quadriceps flexibility.
- 6.** Arm circles: Arms extended, make small circles, gradually increase size. This warms up your shoulders for the demands of jet skiing.
- 7.** Neck rolls: Gently roll your head in a circular motion, clockwise then counterclockwise, releasing tension in neck and upper shoulders.



- 8.** Wrist rolls: Extend arms make circular motions with your wrists. This loosens joints and preps them for gripping handlebars.
- 9.** Ankle rolls: Lift one foot, rotate your ankle clockwise, then counterclockwise. Repeat with other ankle. This prevents injuries and improves balance.
- 10.** Jump squats: Stand with feet shoulder-width apart, lower into a squat, then jump up explosively. Land softly and repeat. This activates leg muscles, enhances explosive power, and elevates your heart rate.

Incorporate this quick effective warm-up routine into your pre-ride preparation to enhance flexibility, reduce risk of injury, and ensure your body is ready for the physical demands of jet skiing. **PR**

FOR HELP WITH FITNESS DM ME ON
 INSTAGRAM @JETPUMPFIT OR
 KYLA DESROSIERS ON FACEBOOK!

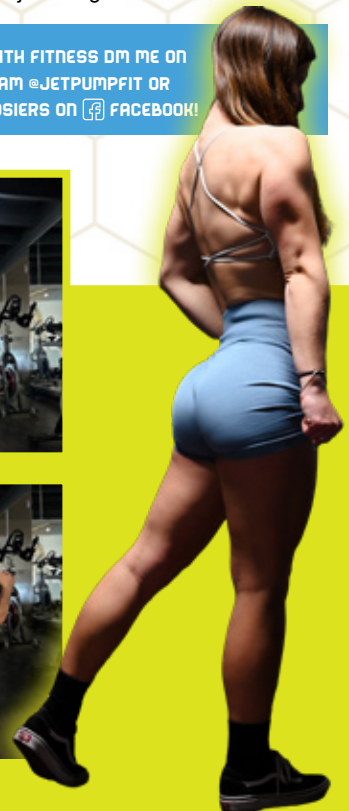

POSSIBLE®

**NUTRITION THAT EMPOWERS
EXTRAORDINARY ACHIEVEMENT
AND STILL TASTES GOOD!**

POWERED BY STANDARD PROCESS®

WWW.MYPOSSIBLE.COM

@MYPOSSIBLEFOODS



LIFE'S A SPORT. FUEL UP.



JACK DUBOIS
FREESTYLE ATHLETE

“Motorsports are very physically demanding and one of the best things we can do for ourselves as athletes is to stay hydrated. This is why I'm so excited about the new POSSIBLE Whole Food Electrolyte!

I was personally involved in the development of this product, and it all started on our organic farm with the mission of learning to grow Atriplex, a new crop that very few people grow. This product was not built around isolated ingredients but rather crops grown with naturally occurring minerals and electrolytes.

This product has helped me avoid cramping and arm pump while allowing me to achieve my full potential as a motorsport's athlete. I envision a future where motorsports athletes prioritize their health and nutrition with the same dedication as athletes in sports like soccer, football, and baseball.”

Air Intake System Upgrades – 101



POWER FILTER ELEMENT



POWER FILTER KIT

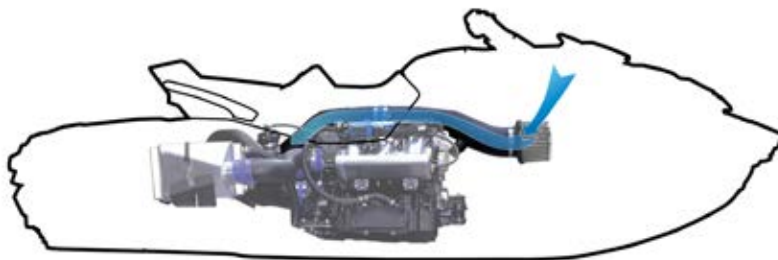

POWER FILTER AIRFLOW

Watercraft manufacturers have incorporated restrictive mesh filter elements into their intake manifolds which restricts air from entering the intake manifold. On some PWC models, this mesh element is prone to becoming dislodged and can cause engine damage. To counter this, RIVA Racing offers Intake Manifold Upgrade Kits that enable you to remove the problematic mesh inserts providing increasing performance and reliability. For Yamaha engines, a tapered billet sleeve is provided that creates a smooth transition after the mesh element is removed. Sea-Doo engines also benefit greatly from the installation of an Intake Manifold Upgrade Kit when seeking more power.

Modifying your Air Intake System is a gateway step to unleash the power of your watercraft's engine. It allows you to take advantage of additional upgrades such as ECU tuning, supercharger upgrades, oversized valves and aftermarket cams. **PR**

FOR MORE INFORMATION ABOUT HOW TO UNLOCK THE FULL POTENTIAL OF YOUR WATERCRAFT'S ENGINE PLEASE VISIT RIVARACING.COM.

Upgrading the air intake system on your watercraft is a critical step on your quest for more performance. Stock PWC intake systems consist of an airbox that typically contains restrictive baffles or filters and small diameter intake ducting that limits air flow. They allow just enough air into your engine to meet the manufacturer's intended performance specifications.

RIVA Racing offers a complete line of 'Power Filter' Kits designed to increase and optimize air flow to your engine producing more horsepower and torque. RIVA's air intake kits feature an oversized stainless steel mesh filter that allows a massive amount of air to enter your intake system. The element is certified to meet U.S. Coast Guard 'SAE J1928' safety requirements.

RIVA air filters are positioned close to the stock hull ventilation inlets so that cooler air is collected. Air flow is directed towards your engine via high-volume, precision-formed ducting. A contoured velocity stack connects the air ducting to your engine's supercharger inlet or, in the case of naturally aspirated engines, directly to the throttle body. The tapered design of the velocity stack accelerates air flow for improved engine efficiency.

While aftermarket air intake systems deliver more air to your engine, there's a chokepoint between the air intake system and the engine that can be easily opened up.

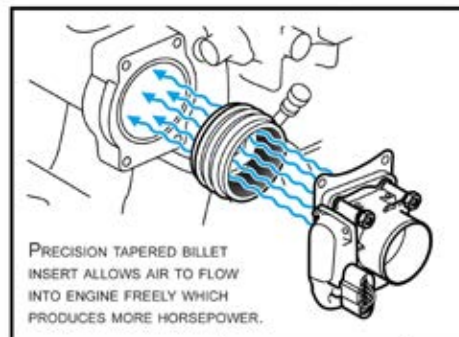

RESTRICTIVE MESH ELEMENT REDUCES AIR FLOW INTO ENGINE ROBBING IT OF HORSEPOWER.

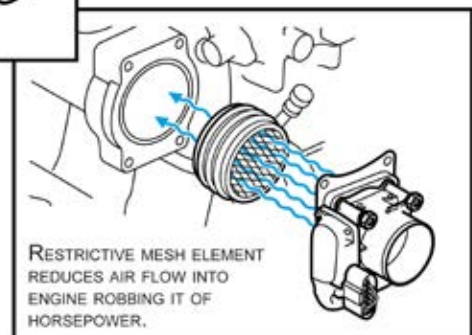

INTAKE-MANIFOLD-UPGRADE

Jetting into the Future:

Introducing Children to Jet Skiing and Competitive Riding

By: Theresa Galdony
Images: XtremeRiderz.com



Jet skiing isn't just an exhilarating water sport; it's a gateway to adventure, discipline, and potential stardom in the world of competitive racing. Introducing children to jet skiing can be both fun and beneficial. But how do you go beyond weekend rides and prepare your child for the fast-paced world of competitive or professional jet ski riding? Here's a guide to helping your child turn their passion for jet skiing into a lifelong pursuit.

STARTING YOUNG: THE BASICS

The first step in introducing children to jet skiing is ensuring they are comfortable in the water. Swimming lessons are a must, to build confidence and teach essential safety skills. Once they're ready for a ski, begin with age-appropriate models. Smaller, less powerful jet skis are designed for younger riders, providing a safer environment to learn control, balance, and maneuvering.

SAFETY FIRST: GEAR AND RULES

Safety is paramount. Equip your child with a well-fitted life jacket, and ensure they wear it every time they ride. Protective gear like gloves and wetsuits can prevent injuries. Educate your child on the importance of following all safety guidelines, such as maintaining a safe distance from other riders, avoiding dangerous stunts, and understanding local waterway rules.

BUILDING SKILLS: PRACTICE MAKES PERFECT

Consistent practice is key to developing strong riding skills. Encourage your child to spend time on the water, focusing on different aspects such as speed control, turns, and navigating waves. As they become more comfortable, introduce them to riding in various conditions, from calm waters to choppy seas, to build their adaptability.

INTRODUCING COMPETITION: LOCAL AND REGIONAL RACES

Once your child masters the basics, consider entering them in local races to introduce them to competition. These events teach race protocols, sportsmanship, and handling pressure, while offering a chance to network with other young riders and passionate families.



THE NEXT LEVEL: ADVANCED TRAINING AND MENTORSHIP

As your child advances, consider professional training from coaches or riding schools specializing in competitive jet skiing. They can help refine technique, boost speed, and develop race strategies. Connecting with experienced mentors also offers valuable insights and inspiration.

STAYING MOTIVATED: BALANCING FUN AND DISCIPLINE

While it's important to encourage your child's ambition, it's equally crucial to ensure they enjoy the sport. Balance structured training with free rides, where they can have fun without the pressure of competition keeping the sport enjoyable as they grow.

PREPARING FOR THE PROFESSIONAL ARENA

Becoming a professional rider requires more than just skill. Physical fitness, mental toughness, and a deep understanding of the sport are crucial. Encourage strength training, agility exercises, and mental conditioning to prepare for the demands of competition.

CONCLUSION: JETTING TOWARD THE FUTURE

Introducing your child to jet skiing can launch an exciting journey, whether as a hobby or a career. With a solid foundation, regular practice, and a mix of discipline and fun, they could become a champion. Start early, nurture their passion, and watch them jet into a future of thrilling possibilities! **PR**



About the Author: Theresa Galdony, President of ColorAmerica (www.coloramerica.com), a renowned marketing and branding agency, has dedicated over 20 years to working with providers in the watercraft and powersports industry. Her latest venture, Xtreme Riderz (www.xtremesiderz.com), offers a wide range of products specifically designed for powersports enthusiasts. Through her extensive expertise and commitment to the industry, Theresa delivers valuable insights and practical advice to enhance the riding experience for enthusiasts of all ages.

PRESENTED BY:



JACK 'THE RIPPER' COBB

MEMBER HH3
RACE TEAM

Photos and video:
Gregory Cobb



Watch Larry 'The Ripper' Rippenkroeger bestow 'Ripper' title to Jack



AGE: 13

HOMETOWN:

Born and raised in Lake Havasu City, Arizona

SKI:

2005 SXR 800 for the last year; recently finished a new build of a 2020 Superjet I will be racing from now on.

RACE #: 3

RIDING: Racer and recreational rider

LATEST ACHIEVEMENTS:

Lots of training for racing. And a lifelong friend took an interest in riding, so I have been helping him learn to race over the summer. He has learned so much and is getting better every day. He will be lining up soon at a race.

I started riding with my dad at 8 years old on a Kawasaki 440. Last year, I decided to race, and we got my SXR 800 from the legendary Haulin' Harry Goatcher! I had the privilege of Harry not only becoming my personal coach and friend but also bringing me into his racing team HH3 Race Team. Other training on the water includes many lessons learned by my sponsor and friend Chris Hagest of Pro Watercraft Racing. My other hobbies include riding scooters at the skatepark and fishing.

MEMORABLE WATER MOMENT:

Has to be my first ever race in Parker, Arizona at the start of the season and getting a first-place win!

FAVORITE RIDING LOCATIONS:

Body Beach, riding the river to the Sandbar in Havasu and definitely on the river in Parker.

SPONSORS:

Ultimate Watercraft Performance, Adrenaline Trailer, Pro Watercraft, Jettrim, VSS Racing, Bove's Pasta Sauce, and GC Designs



THRILLS, TRIUMPHS, and Brotherly LOVE

at Cayman Islands South Sound Dock:

2024 CIWA NATIONAL TOUR

The 2024 CIWA National Tour made an electrifying stop at South Sound Dock Cayman Islands. With stakes higher than ever, riders across all classes showcased unparalleled skill and determination, setting the stage for an impressive day of competition for round 3.

Beginners class set the tone for a memorable race. Rene Ortega, despite encountering early troubles, showcased resilience and skill. Fighting through mechanical issues and a shaky start, Ortega's determination paid off as he surged ahead to clinch first-place. Hot on his heels was Michael Woods, second with consistent performance, followed by Ryan Dixon in third, all demonstrating commendable prowess on the water.

Andre Massias, the rookie of the season, stunned spectators with a stellar performance in Novice class. Displaying raw talent and unwavering focus, Massias claimed the top spot, marking a significant milestone in his burgeoning career. Allenger McLaughlin, Jr. followed closely, taking second, while Brandon Elliott rounded out the podium in third. Massias's triumph highlighted his potential and intensified the competition in this category.

The Amateur class saw a fascinating mix of local and international talent. Leroy Whittaker emerged victorious, dominating with impeccable skill and strategy. Close behind was Ben Mantel, a dedicated rider from Florida, whose impressive second-place finish underscored the international appeal of the CIWA National Tour.

Joshua Watler took third, adding to the local pride showcasing the depth of talent in the Cayman Islands.

Pro Class was the highlight of the event, delivering drama and excitement at every turn. Jordan "JJ" McLean, who struggled to podium the first two rounds, finally found his stride. Overcoming past setbacks, McLean delivered a masterclass in speed and control, securing a well-deserved first place. Wayne Cato, Jr. put up a strong fight for second, while Nathan McLean, current Pro class leader, finished third. Despite facing issues, Nathan was thrilled to share the podium with his brother, adding a heartwarming chapter to the day's narrative.

The competition at South Sound Dock underscored the intense rivalry among Amateur and Pro class leaders as they vie for a coveted spot at the 2024 IJSBA World Finals. **PR**



By: Mike Young,
Pro Sports Announcer



PRO





AMATEUR



BEGINNER



NOVICE





LEGIT IN PRINT

6 ISSUES ONLY \$49.99 **PLUS 2 FREE STICKERS**

THE ONLY PWC MAGAZINE THAT HAS IT ALL!

PRORIDER NOW OFFERS:

PRINT

- THE REAL DEAL, LEGIT IN PRINT
- DELIVERED TO YOUR DOOR
- 2 FREE STICKERS
- 1 YEAR (6 ISSUES) ONLY \$49.99*

DIGITAL

- VIEW INSTANTLY WITH PC, IPAD AND MOBILE DEVICE
- NO APPS NECESSARY
- 1 YEAR (6 ISSUES) DIGITAL SUBSCRIPTION ONLY \$14.95

BOTH

- THE BEST OF BOTH WORLDS
- 1 YEAR (6 ISSUES) LEGIT IN PRINT
- 1 YEAR (6 ISSUES) DIGITAL
- 2 FREE STICKERS
- ALL FOR \$59.99*

*US PRICES ONLY, INTERNATIONAL OPTIONS AVAILABLE

SUBSCRIBE ONLINE AT:
WWW.PRORIDERMAG.COM



Name: _____

Address: _____

City: _____ State: _____ Zip: _____

Email: _____

MAIL A CHECK OR MONEY ORDER TO:

Pro Rider Watercraft Magazine
191 Wilson Road
Jackson, GA 30233

PR PHOTO CONTEST

Pro Rider Sep / Oct 2024 Gear Giveaway

PRO RIDER GEAR KEEPS YOU LOOKING FAST ON AND OFF THE WATER. *

*Individual results may vary

HOW TO WIN

Submit your best high resolution PWC related photos to CONTEST@PRORIDERMAG.COM with "Pro Rider Entry" in the subject line. Photos that have not yet been posted to any social media sites will have greater chances of winning. Open to amateur photographers only. Good luck!

*Products and sizes may vary.



VISIT WWW.PRORIDERMAG.COM FOR MORE INFORMATION OR "LIKE" PRO RIDER WATERCRAFT MAGAZINE ON FACEBOOK.

WIN THIS GEAR!

This issue's photo contest winner will receive a Hydro-Turf PWC Mat Sheet and an official Hydro-Turf t-shirt, compliments of our good friends at Hydro-Turf, a leader in the performance traction mat and PWC seat cover industries for more than 30 years! Hydro-Turf is committed to providing the highest quality EVA foam and marine upholstery products on the market. Upgrade your PWC, Jet Boat, Hunting Boat, and SUP today!



Check out the entire line of Hydro-Turf products at

[HTTPS://WWW.HYDROTURF.COM/](https://www.hydroturf.com/)



Conquering the Waves:

When the sun emerges over the shimmering waters of Lake Havasu, thrill-seekers come out to play. In recent years, a new wave of adrenaline junkies has emerged: teenage girls taking charge of the jet ski racing scene. Among them, GoFastGirls (GFG) Ambassadors Britton Reinhard and Taylor Smith, are not just riding waves but conquering them with skill, determination, and passion for extreme water sports.

Traditionally dominated by men, a new era is dawning with teenage girls making their mark in racing. Fueled by a passion for speed and thirst for adventure, young women are challenging stereotypes and shattering barriers.

Britton:

At 13, Britton has a fearless attitude and natural talent and has quickly established herself as one of the most exciting young talents in the sport. Her aggressive riding style and bold approach to competition have earned her legions of fans and a reputation as a rising star.

GoFastGirls Teen Ambassadors

BRITTON REINHARD AND TAYLOR SMITH
Lead the Charge in Havasu Jet Ski Races

PHOTO:
Kenny Wong
KENW SPORTS PHOTOS



PHOTO:
Rain Porter
121 PHOTO

Taylor:

A force to be reckoned with at just 16, Taylor, already a seasoned veteran of racing with a natural talent for navigating waves and intrepid approach to competition, has quickly become a top contender earning the respect of peers and admiration of fans around the world.

GFG Ambassadors shine on the water each year as Lake Havasu plays host to some of the most thrilling jet ski races in the world. And each year, GFG ambassadors Britton and Taylor are among the top competitors inspiring a new generation of young girls to chase their dreams and conquer the waves. **PR**

#GOFASTGIRLS #JETSKIRACING
#PRRIDERMAGAZINE



YAMAHA



NIELSEN

ENTERPRISES

EST. 1969

  **Nielsens.com**

847.356.3000

829 N Milwaukee Ave. Lake Villa, IL 60046

SEA•DOO®



NIELSEN

ENTERPRISES



EST. 1969



Nielsens.com

847.356.3000

829 N Milwaukee Ave. Lake Villa, IL 60046

* TM and the BRP logo are trademarks of Bombardier Recreational Products Inc. or its affiliates.

NAMURA[®]

T E C H N O L O G I E S I N C

SEA-DOO SPARK PISTONS AND GASKETS

**ARE NOW
AVAILABLE**



FIND ALL YOUR PERSONAL WATERCRAFT
ENGINE PARTS NEEDS ON OUR WEBSITE

WWW.NAMURA.COM

